

THE MB-86EI SYSTEM OF FIREPROOF WINDOWS, DOORS AND PARTITION WALLS

1. DESCRIPTION OF THE STRUCTURE

The MB-86EI system of fireproof windows, doors and partition walls with thermal insulation is intended for execution of external fireproof barriers equipped with operable windows, doors and walls of main fireproof class EI30, EW30, EI15 according to the standard PN-EN 13501-2. The system has been classified as non-fire propagating (NFP). The structure of the system is based on the MB-86 system, hence the windows and doors feature high thermal and acoustic performance as well as high tightness to water infiltration and air permeability. This system meets all provisions of applicable regulations and standards, especially the ones concerning energy conservation and environmental protection.

Application of glazed fireproof barriers in building industry should be subject to the technical documentation of the building, designed in accordance with applicable standards and regulations.

CHARACTERISTICS OF THE MB-86EI SYSTEM:

- The construction of the system is based on aluminium profiles with thermal spacers of the MB-86 system. The constructional depths of window profiles is: 77 mm (frame) and 86 mm (sash) and of the door profiles: 77 mm (door frame) and 77 mm (door leaf).
- The profiles applied in this system have three-chamber construction, the core of which is formed by an insulating chamber placed between thermal spacers 43, 42 or 30.5 mm wide.
- Elements of the GKF fire insulation are inserted in the internal chambers of aluminium profiles.
- The system comes with an option incorporating a barrier between thermal spacers dividing the inner air chamber into two parts, as in the MB-86 SI system, thanks to which high insulation performance is achieved. The profile can be made in two variants: with a co-extruded partition or inserted between thermal pads.
- Heat transfer coefficients U_f of frames in windows attain very low values, which only marginally exceed the values attained for analogous frames of the base MB-86 system.
- High tightness to water penetration and air infiltration, as well as excellent thermal insulation performance has been possible to achieve mainly due to the special shape of two-component central gasket (with cellular insulating part) as well as glazing and closing gaskets.
- Most gaskets, just like in the MB-86 system (e.g. glazing and internal closing gaskets) are fitted as continuous stripping, without any corner trimming. The ends of gaskets are joined in mid-length of the top rail of the window frame. The central gasket is trimmed at an angle of 45° and glued in the corners or trimmed at an angle of 90° and glued to a rubber corner. The central gasket is also available in the form of a vulcanised frame. Such manner of gasket fitting guarantees very high tightness to water penetration and air infiltration.
- Closed shape of glazing beads, both in the Standard and Prestige versions allow for secure installation of heavy insulating glazing units, consisting, inter alia, of fire-resistant glass panel. Positioning rollers made of EPDM are fitted in the said glazing beads to facilitate the installation of glazing beads in the window frame.
- Internal glazing gaskets are deep-fitted in glazing beads, which is why they are hardly visible from the inside.
- Ranges of glazing thickness possible to achieve: window frame and door leaf – from 41 to 61 mm, window sash – from 41 to 70 mm. Glazing shims are made of fireproof material.
- The glass panels are additionally protected on the outside with steel holders, screwed to the inner and outer profile with sheet metal screws.
- Application of the standard Euro grooves makes it possible to accommodate most hardware types available on the market, intended for both aluminium and plastic windows.
- Hardware fitted in the system should have approval for use in accordance with regulations applicable in the country where the product is installed.
- Compound profiles of the MB-86 EI version may be subjected to the process of powder coating or anodic oxidation.
- Corner connections are executed with the use of corner cleats and crimping or pinning and gluing with two-component glue CORALGLUE®). Crosswise joints of the “T” type are performed by pinning of crosspieces with the inserted corner cleats and gluing with CORALGLUE®).
- Both concealed and traditional hinges may be fitted in windows of this system. Handles may come either with or without an escutcheon.
- Each structure of the MB-86EI system intended for external development must be equipped with an efficient system of ventilation and drainage deflecting water from the glass chamber.

- The technology of fabrication of the construction is simplified as much as possible, hence high time efficiency is achieved in window fabrication.
- Tooling (e.g. drilling templates, presses or blanking dies) may be used for most workings. All elements of the tooling applicable in the MB-86 EI system are contained in the section *Tooling*.
- Maximum dimensions of window and door sashes significantly exceed the values recognised as the standard ones.
Maximum weight and dimensions are presented in the section *Structural Analysis*.
- The product range of window and door structures is shown in the section *Structural Analysis*.
- The MB-86EI system is fully compatible with the MB-86 system. (they share the same profiles, details, many types of the same hardware, workings, etc.).

Conformance with the instructions presented in this catalogue guarantees that the finished product will meet expectations of users over many years' operation.

In the event of any queries or doubts, ALUPROF S.A. specialists are always ready with their assistance and advice.

Each structure made of elements of the MB-86 EI system must have approval for use in accordance with regulations applicable in the country in which it is mounted. A reference document used by the manufacturer to declare performance properties at the stage of marketing the fire-resistant product strictly defines the range of structures allowed for use in a particular country, including detailed solutions. Only solutions presented herein may be applied in the fabrication of the product.

Solutions presented in this catalogue are subject to additional restrictions resulting from approvals for use applicable in the country where they are used. The said restrictions are specified in supplements, which form an integral part of this catalogue.

NOTE:

Any rights to the present publication and rights to utility models included herein are vested in ALUPROF S.A. and are subject to protection pursuant to the regulations on utility models and copyrights protection.

ALUPROF S.A. reserves the right to make alterations and add supplements in view of further development of the system and its continual technical improvement.

The presented publication shall not be reproduced or copied in any way whatsoever without a prior written consent of ALUPROF S.A

2. TECHNICAL DESCRIPTION OF MATERIALS AND RAW MATERIALS

2.1. ALUMINIUM PROFILES

Aluminium profiles are made during the forming process of aluminium alloy EN AW-6060 as per PN-EN 573-3, T66 temper, according to the standard 515 or from the alloy AlMgSi0,5 F22 as per DIN 1725 T.1.

Profiles are conformant with the PN-EN 755-1 standard.

Mechanical properties of profiles comply with PN-EN 755-2.

Tolerances on dimensions and form - according to PN-EN 12020-2.

Surfaces of profiles should be finished with anodic oxidation coatings according to the Qualanod requirements or with polyester powder coatings according to the Qualicoat requirements - as protection against corrosion.

2.2. THERMAL SPACERS AND BARRIERS

Thermal spacers and barriers are made of polyamide profiles strengthened with fibreglass PA 6,6 GF25 as per DIN 16941 T.2 (they have manufacturer's certificate).

Chamber thermal spacers feature very high resistance and their thermal expansion is similar to aluminium, which excludes the risk of joint deformation and prevents tearing of joints on the polyamide / aluminium border when the face of buildings is exposed to significant changes in temperature.

Properly crimped thermal spacers ensure such resistance of compound profile as provided under the relevant standard concerning resistance of the compound profile.

2.3. FIRE INSULATION ELEMENTS windows, however, must be installed only in a vertical position.

Infills are made of GKF plasterboards. Fire-resistant expanding strips are cut off from boards or supplied in rolls. These elements are performed in accordance with the applicable standards and relevant technical approvals

2.4. GASKETS

Glazing and closing gaskets are made of synthetic rubber EPDM as per DIN7863 and working standard DIN7715 E2 or ISO3302-1. Gaskets are connected with each other in the process of gluing or vulcanising.

2.5. GLASS PANELS

Transparent areas are glazed with special glass panels, selected in such a manner that the assembly conforms to the requirements set for the relevant fireproof class EI15 or EI30, thermal standards and sound-proof performance of rooms.

All glass panels installed in the MB-86 EI system must have approval for use in respect of fireproof structures according to regulations applicable in a particular country. Maximum dimensions of glass panels should be consulted with the glass panel supplier.

2.6. ALUMINIUM SHEETS

Aluminium sheets are made of aluminium alloy as per the standard PN-EN 485, subjected to anodic oxidation or powder coating, used for sheet working and finish.

2.7. FIXATION ELEMENTS

Fixation elements (self-tapping and self-drilling screws, bolts, rivets, nuts, washers) applied to make connections, are made either of stainless steel or are zinc-coated in accordance with the standards referred to in the system documentation.

2.8. HARDWARE

Hardware should be mounted onto the window profiles in accordance with the system documentation or the documentation of the hardware manufacturer. Hardware should be adapted to the dead weight of sashes, their operating load and dimensions.

2.9. AUXILIARY MATERIALS

Auxiliary elements (glazing shims, glues, mineral wool and silicones used to seal joints) – in accordance with the system documentation.

3. SUPPLEMENTARY INFORMATION

3.1. GRAPHIC PRESENTATION OF DOOR AND WINDOW TYPE OF OPERATION

A figure or a drawing always shows the view of the construction as seen from the outside, i.e. where the glazing beads are not visible.

3.1.1. Sash swing direction

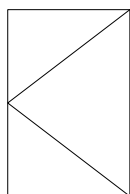

outward

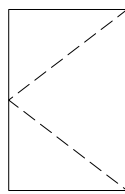

inward

3.1.2. Graphic presentation of window types

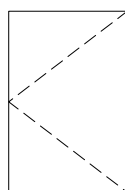
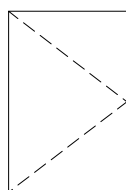

fixed

casement - left
hand operationcasement –
right hand
operation

tilt & turn



bottom-hung

3.2. CONSTRUCTION OF PROFILES

The profiles applied in the MB-86EI system feature three-chamber construction, the core of which is an insulating chamber placed between thermal spacers 43 or 42 mm wide. The central chamber of each compound profile is divided into two separate chambers by means of thermal barriers. Chambers featuring the same thermal and resistance parameters come in two variants. The insulating insert separating the mid chamber into two parts must be placed between thermal breaks or must be joined with one of the thermal breaks. The system of connections with thermal spacers enables application of dual-colour profiles – different on the inside and different on the external part of the façade. The chamber-shape of thermal spacers guarantees high rigidity, very good thermal insulation properties and proper drainage of internal chambers of the profile.

3.3 EXPANSION JOINTS IN DOOR LEAF PROFILES

In certain conditions of operation of large-dimension products with thermal insulation there may incidentally occur an undesirable physical condition involving leaf profiles bending.

Below is shown a set of conditions causing an undesirable profile bending:

- dark colour of profiles,
- door installed in a building featuring southern or south-west exposure,
- putting the product at risk of direct exposure to the sun radiation (lack of roof compliant with the applicable law or building development or trees providing shading,
- dark colour of the door infill
- long horizontal or oblique crosspieces in the door leaf.

Profile bending consists in uneven elongation of the external and internal profile due to various temperatures. Paradoxically, the better thermal insulation of combined profiles, the more noticeable profile bending. The largest deflection occurs when the insolation reaches the highest value. In the hours that follow the profile resumes its previous shape.

However, excessive bending of profiles in winter conditions is closely connected with the door leaf dimensions and the applied hardware (the bigger the door, the larger the deflection).

In order to avoid thermally bending of large leaves, at least one of the above listed factors should be eliminated, reduce the dimensions of the door and use dilatation profiles of the door leaves.

3.4. SOUND INSULATION

The values of sound insulation index $R_w(C,C_{tr})$, R_{A1} and R_{A2} depend on the applied glass unit and the type of the structure.

3.5. AIR PERMEABILITY

- Air permeability of windows and balcony doors in external development, according to PN-EN 12207 standard, has been classified as class 4.

3.6. STRENGTH CALCULATIONS

Proper selection of optimal construction profiles should be based on the guidelines contained in the section *Structural Analysis*. That section also provides information regarding maximum dimensions of sashes and leaves, preconditioned by the type of applied profiles, hardware, etc.

3.7. MB-CAD and MB-SOFT SOFTWARE

Computer software MB-CAD and MB-SOFT is a convenient tool to quickly design and prepare offers, production cuttings (containing profiles, accessories and infills), to carry out structural analysis, material orders, etc. Detailed information about the software and how to acquire it is available on the premises of Aluprof S.A.

3.8. WORKING

Decorative surfaces of profiles should be covered with protective foil for protection from any working-related damage. Tolerances for linear and angular dimensions without individual tolerance indications, as per PN-EN 22768-1, class of tolerance – m (medium accuracy level). Any splinters which occur in the process of working should be absolutely deburred.

3.9. STORAGE AND TRANSPORT

- Storage

Aluminium profiles, details, infills, glass panels, windows and doors should be stored in dry rooms so as to protect them against mechanical damage and against damage to the anodised or painted coatings

Elements of fire insulation GKF and CI should be stored in original packaging in a vertical position. Where re-packing is required, the following principles should be followed:

- the inserts must lie in a horizontal position on a firm and flat surface (e.g. on a chipboard),
- subsequent layers should be interleaved with PE foil (e.g. thin drop sheet),
- maximum number of layers - 25 in one packaging, but the stack must not be higher than 600 mm.

Products should be stored in warehouses in normal weather conditions, i.e. in the temperature between 5° and 25°C and humidity ranging between 50 and 80%.

After opening the package and taking the required number of inserts, the package should be covered with protective foil. It should be protected against dampness and excessive drying up. The inserts should be carefully carried to avoid any possible damage – breakage.

The principles of storage and application of an expanding tape are contained in the section *Working*.

- Transport

Aluminium profiles, details, infills, glass panes, windows and doors may be transported by any means of transport provided they are protected against soiling, dust, weather conditions and exposure to any damage during transportation.

3.10. ASSEMBLY GUIDELINES AT THE BUILDING SITE

ALUPROF MB-86EI doors, walls and windows* can be installed in the following mounting constructions:

- Rigid mounting construction min 120 (100*) mm thick and of min. density 650 (600*) kg/m³
- Aluminium profile wall of Aluprof MB-86EI system.

The MB-86EI windows and doors, however, must be installed only in a vertical position.

Installation of partition walls, windows and doors on a building site should be carried out in the temperature not lower than 5°C. During its installation, the structure should be protected against exposure to weather conditions, such as water, snow and any type of mortar and builders dust.

The gaps formed between the window/door and masonry should be filled with non-flammable mineral wool of min. density 70 kg/m³ or with any other fireproof filling, allowed for use in fireproof structures and then they should be covered with non-flammable material (e.g. plasterboard, concrete-lime plaster, fireproof caulk, aluminium profile, steel profile or metalworking). Installation must be compliant with the relevant approval documents. Detailed information regarding the assembly of products is contained in the section *Examples of Development*.

WARNING:

Lime, cement, alkaline and cleaning substances (e.g. bleaches, abrasive pastes) have particularly harmful effect on aluminium profiles, especially on decorative protective surfaces. Thus any “wet” works must be limited to the minimum. Should mortar be brought into contact with the surface of aluminium, it must be immediately washed off (its hardening must not be allowed). Failure to wash off the mortar will result in permanent discolouring and will damage the surface.

In places of contact between aluminium and other metals or their alloys, electrochemical oxidation of aluminium occurs. The process of this kind of corrosion is particularly quick when there is a lot of moisture in the surrounding atmosphere. Therefore aluminium should be separated from other metals with an insulating layer.

3.11. HARDWARE ADJUSTMENT

After mounting sashes, their position in relation to the window frame and adjacent sashes (adjustment of hinges, friction stays) should be adjusted, then adjustment of hardware elements cooperating with each other (strikers, bolts) should be made. The sashes should be levelled and the distance between the profiles of adjacent sashes should be the same.

3.12. MAINTENANCE

Anodised or paint-coated aluminium profiles should be washed with a soft cloth and mild cleaning agents. Alkaline-based liquids are not allowed, as they may damage the anodic oxidation coatings or paint coatings. Cleaning agents with pH below 5 or over 8 must not be used. While cleaning, the temperature of coatings and the temperature of water must not exceed 25°C. After each cleaning the surface must be immediately rinsed with clean and cold water.

Regular cleaning prevents formation of obstinate and difficult to remove dirt.

Maintenance of hardware should be performed in accordance with the instructions provided by manufacturers of the hardware.

3.13. CATALOGUE UPDATES

The catalogue should be updated by downloading PDF files from <https://aluprof.com> in the authorised section *Catalogues*

3.14. AVAILABILITY OF CATALOGUE PRODUCTS

Rules and availability dates of the elements presented in the catalogue have been specified in Aluprof SA' price lists, included in the authorised section of the website <https://aluprof.com> in the section *Price Lists*.

4. INFORMATIONEN ZUR NACHHALTIGKEIT DER PRODUKTE VON ALUPROF SA

Als führender Hersteller von Aluminiumsystemen legt Aluprof großen Wert auf eine nachhaltige Entwicklung und minimiert die Umweltauswirkungen seiner Tätigkeit. Seit 2014 ist das Unternehmen Mitglied des Global Compact der Vereinten Nationen und verpflichtet sich damit, die Prinzipien der internationalen UN-Initiative in den Bereichen Menschenrechte, Arbeitsnormen und Umweltschutz zu wahren und zu fördern. Aluprof ist nach PN-EN ISO 14001:2015 für sein Umweltmanagementsystem zertifiziert, das das Engagement des Unternehmens für den Umwelt- und Naturschutz bestätigt. Die Systeme von Aluprof entsprechen den Normen und werden im Einklang mit den Anforderungen, die sich aus den gesetzlichen Vorschriften und anderen Umweltschutzverpflichtungen ergeben, hergestellt, und die kontinuierliche Verbesserung des Umweltmanagementsystems verbessert deutlich das Bewusstsein und die Umweltauswirkungen der Unternehmenstätigkeit. Im Jahre 2022 erhielt die Grupa Kęty, zu der Aluprof gehört, eine neue Umweltproduktdeklaration (EPD) für ihre Aluminiumprofile, die die Norm EN 15804 zugrunde liegt und die gemäß ISO 14025 von einem externen Prüfer verifiziert wurde. Die Aluprof Systeme können vollständig recycelt, und die dabei gewonnenen Materialien ohne Qualitätsverlust wiederverwendet werden. Diese Maßnahme trägt wesentlich zur Verlängerung des Produktlebenszyklus bei, was in der Praxis bedeutet, dass der Abfall auf ein Minimum reduziert wird. Wenn ein Kunde ein gebrauchtes Produkt hat, kann er es einfach zu einer Sammelstelle bringen, von wo aus das Material für die Herstellung neuer Aluprof Produkte gewonnen wird. Im Falle von Aluminiumprodukten, die direkt an das Unternehmen geliefert werden, werden sie hingegen sorgfältig sortiert und die Beschichtungen entfernt. Das Material wird dann verschrottet, wodurch das Unternehmen Rohmaterial erhält, das für die Herstellung neuer Produkte wiederverwendet werden kann. Sowohl das von den Sammelstellen als auch das vom Unternehmen gelieferte Aluminium wird an das Presswerk von Grupa Kęty weitergeleitet, wo daraus neue Produkte hergestellt werden.

Aluprof schont also nicht nur die Umwelt, sondern gewährleistet durch Recycling und Wiederverwendung von Materialien auch die hohe Qualität seiner Produkte. Als aktives Mitglied des World Green Building Council und der Deutschen Gesellschaft für Nachhaltiges Bauen (DGNB) unterstützt Aluprof globale und lokale Initiativen zur Förderung der CO₂-armen Bauweise (Low Carbon Construction) und Entwicklung von nachhaltigen Städten. Der Kohlenstoff-Fußabdruck der Aluprof Produktion von Profilen beträgt nur 3,3 kg CO₂e/kg, verglichen mit dem Durchschnitt von 9,0 kg CO₂e/kg der European Aluminium Association (EAA). Aluprof schafft eine nachhaltige Lieferkette und ermutigt seine Lieferanten, eine verantwortungsvolle Umweltpolitik zu verfolgen. Das Unternehmen unterstützt die Entwicklung des grünen Bauens und fördert Technologien zur Reduktion des Energieverbrauchs in Gebäuden, indem es mit dem polnischen Verband für umweltfreundliches Bauen (PLGBC) zusammenarbeitet und als Botschafter des Passivhauses auftritt. Durch diese Aktivitäten setzt Aluprof hohe Standards in der Baubranche und will eine grünere und nachhaltigere Zukunft schaffen.

5. GRAPHIC SYMBOLS USED IN THE CATALOGUE

	Number		Working
	Notes		Compatible elements
	Total area [dm ² /m]		Cut
	Decorative area [dm ² /m]		Glue with two-component adhesive
	Cutting angle [°]		Glue and seal
	Dimension [mm]		Seal with silicone
	Number of items		Glue
	Material		Fill in with: _____
	Standard		Perform by using: _____
	Allen key size		Page

STRUCTURAL ANALYSIS

For the purpose of structural analysis, use the information, methods and graphs contained in the production catalogue MB-86, section 03 (up to page 03-0-20.00).

Additional restrictions are included in supplements that are an integral part of this catalog.

Maximum and minimum dimensions of turn & tilt, tilt & turn, side-hung and bottom hung window single-leaf sashes and balcony doors, based on the tilt & turn hardware.

Maximum dimensions are closely correlated with the profiles of which the sashes are made and they are applicable only with complete sets of hardware and they are subject to the application range of this hardware, presented in the section Hardware and Anti-Burglary Hardware catalogue

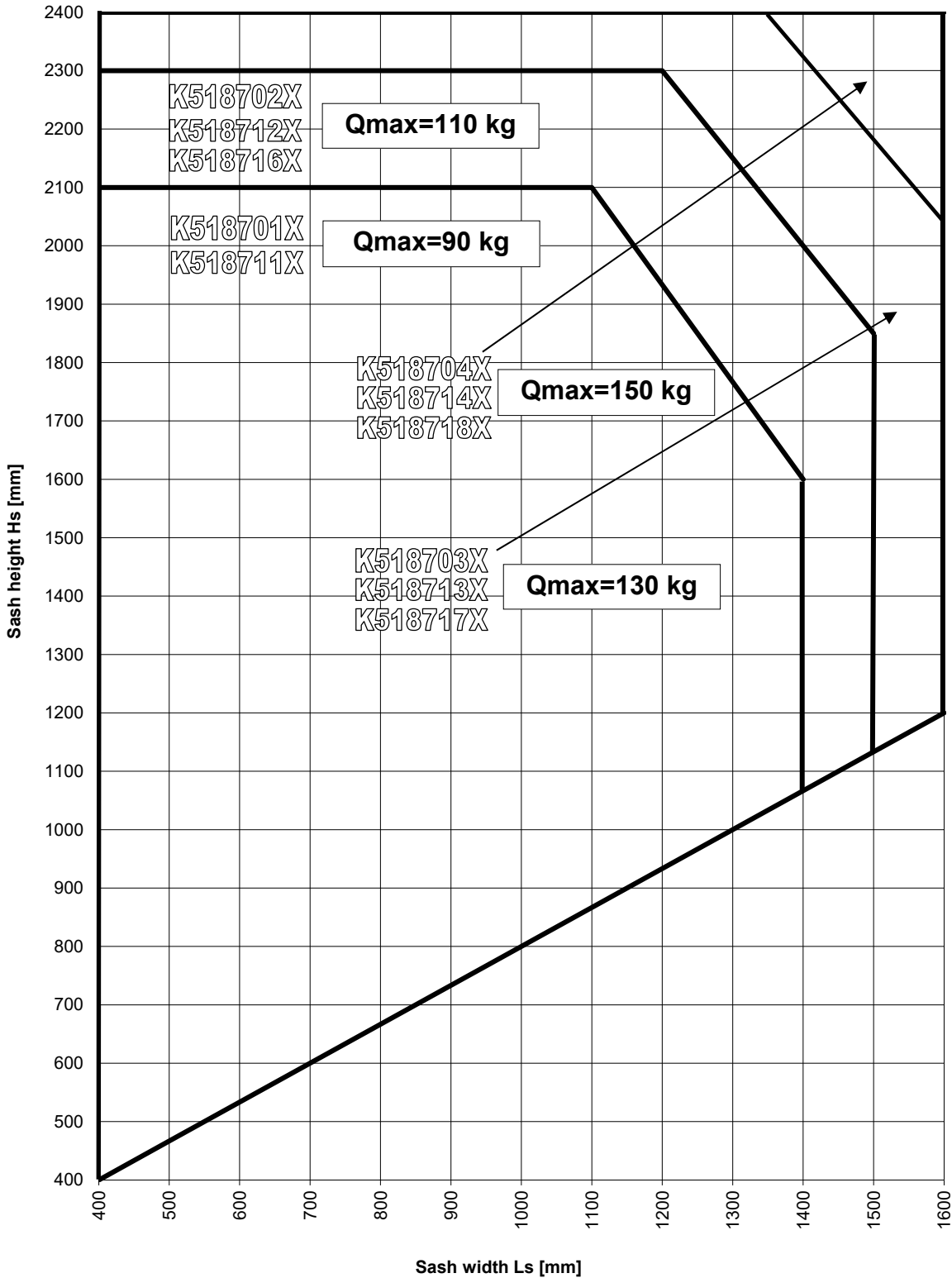

In the case of sashes exceeding the weight or dimensions of the stated ranges, please contact Aluprof S.A.

Maximum and minimum dimensions of turn & tilt, tilt & turn, side-hung and bottom hung window double-leaf sashes and balcony doors, based on the tilt & turn hardware.

Maximum dimensions are closely correlated with the profiles of which the sashes are made and they are applicable only with complete sets of hardware and they are subject to the application range of this hardware, presented in the section Hardware and Anti-Burglary Hardware catalogue

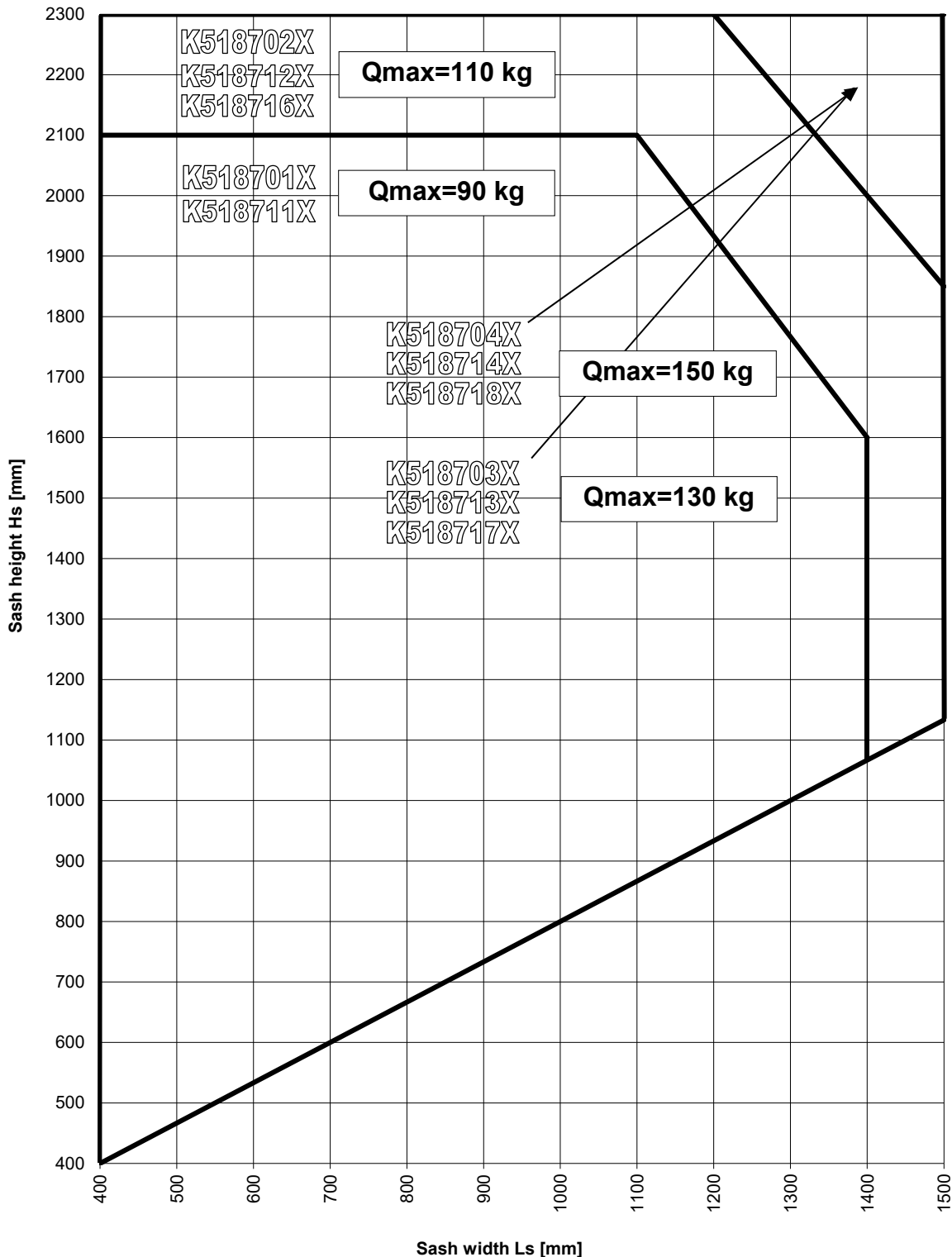

In the case of sashes exceeding the weight or dimensions of the stated ranges, please contact Aluprof S.A.

Maximum and minimum dimensions of sashes of bottom-hung windows

Maximum dimensions are closely correlated with the profiles of which the sashes are made and they are applicable only with complete sets of hardware and they are subject to the application range of this hardware, presented in the section *Hardware* and *Anti-Burglary Hardware* catalogue

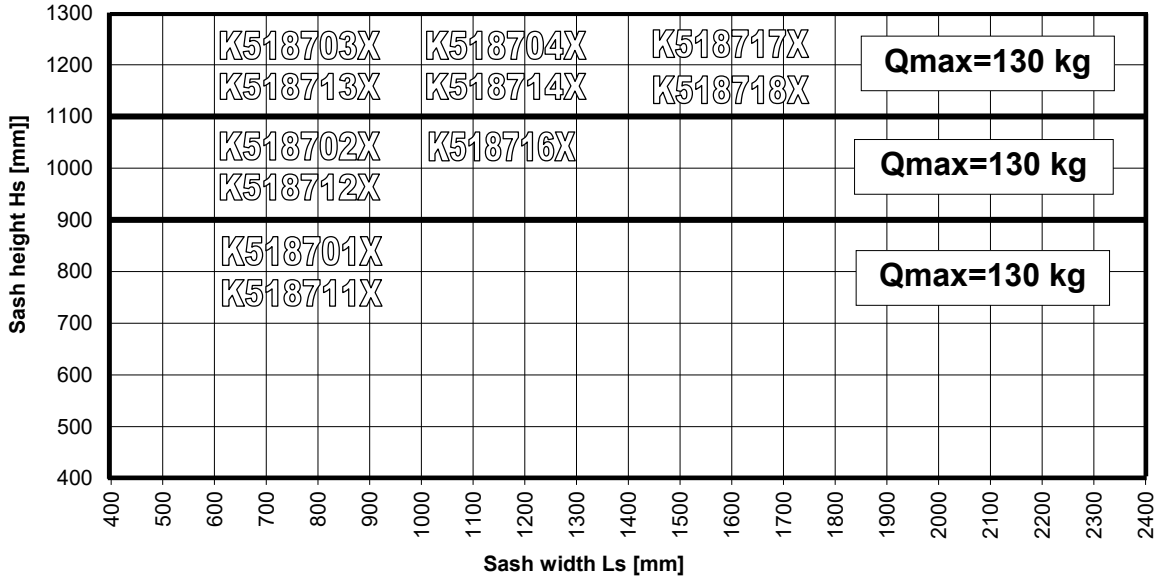

In the case of sashes exceeding the weight or dimensions of the stated ranges, please contact Aluprof S.A.

MB-86EI

EI 30 Maksymalne i minimalne wymiary okien

EI 30 Maximum and minimum dimensions of windows

EI 30 Максимальные и минимальные размеры окон

EI 30 Maximale und minimale Abmessungen der Fenster

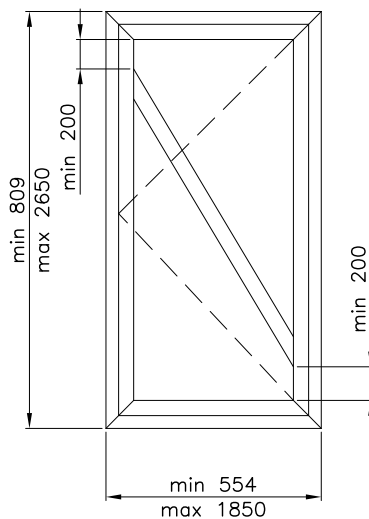
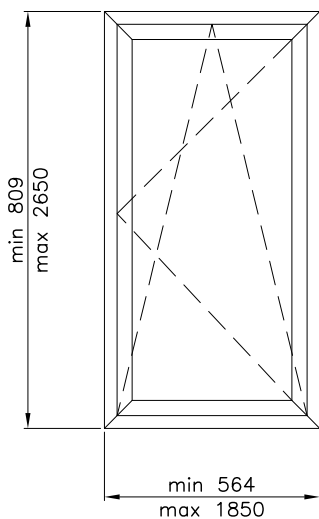

ruchomy stupek
movable mullion

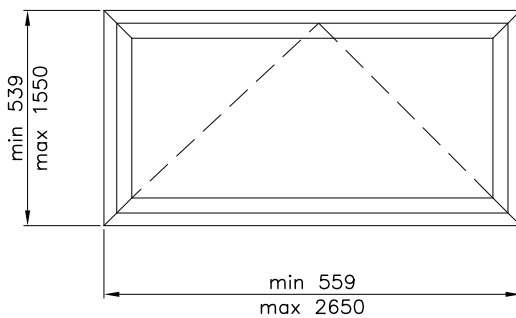
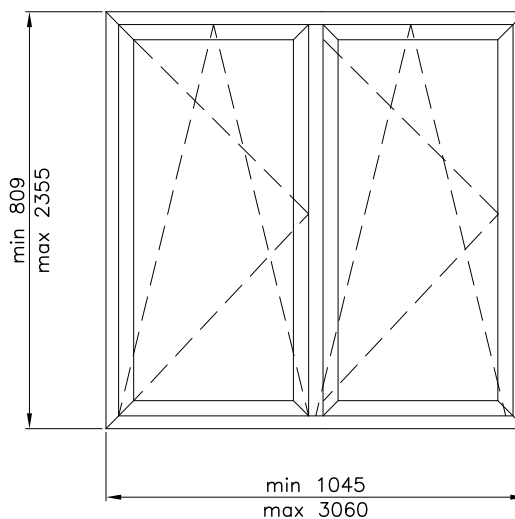
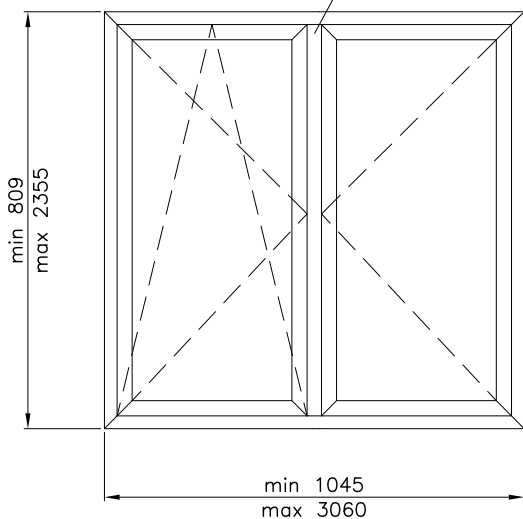

! Maksymalne wymiary szyb konsultować z dostawcą szyb.
The maximum dimensions of the glass panes please consult with the glass supplier.
Максимальные размеры стекол согласовывать с поставщиком стекол.
Die maximale Glasmasse nach der Abstimmung mit dem Glashersteller.

MB-86EI

EI 30 Maksymalne i minimalne wymiary skrzydeł okiennych

EI 30 Maximum and minimum dimensions of window sashes

EI 30 Максимальные и минимальные размеры оконной створки

EI 30 Maximale und minimale Abmessungen der Fensterflügel

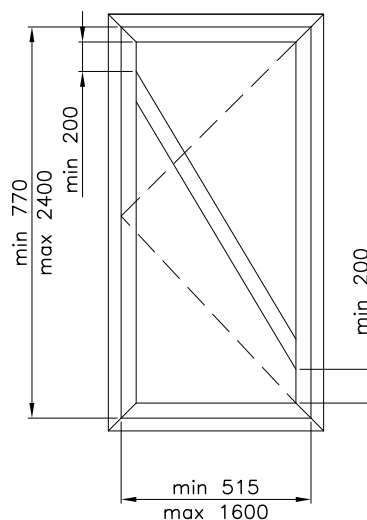
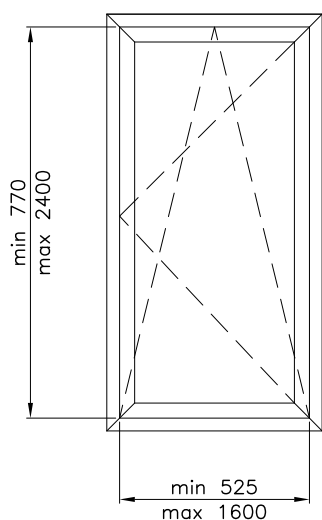

ruchomy stupek
movable mullion
Подвижный импост
Stulppfosten

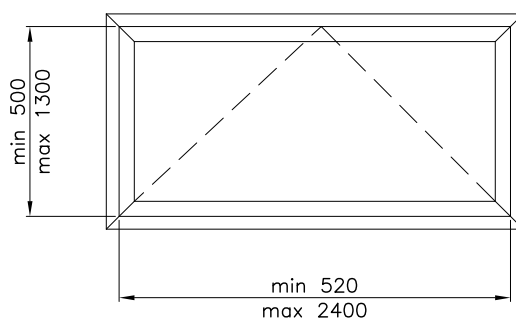
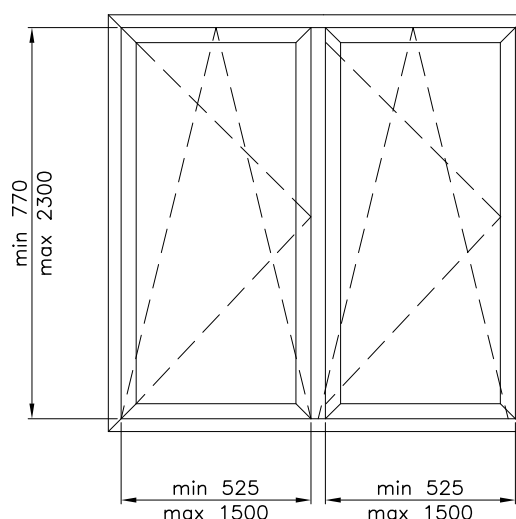
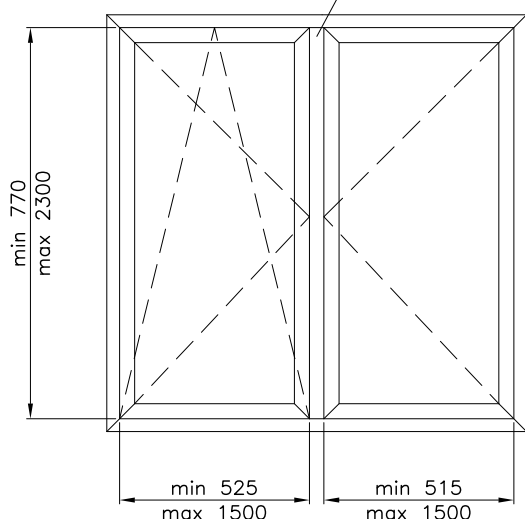

Maksymalne wymiary szyb konsultować z dostawcą szyb.

Wymiar min. i maks. skrzydła okiennego jest zależny od wybranego okucia.

The maximum dimensions of the glass panes please consult with the glass supplier.

Dimension min. and max. window sash depends on the selected fittings.

Максимальные размеры стекол согласовывать с поставщиком стекол. Размер

мин. и макс. створки окна зависит от выбранной фурнитуры.

Die maximale Glasmasse nach der Abstimmung mit dem Glashersteller.

Abmessung min. und max. Fensterflügel hängt vom gewählten Beschlag ab.

MB-86EI

EI 30 Maksymalne wymiary doświetli, naświetli

EI 30 Maximum dimensions of sidelights, toplights.

EI 30 Максимальные размеры Бортовые огни.

EI 30 Maximale Abmessungen der oberlicht.

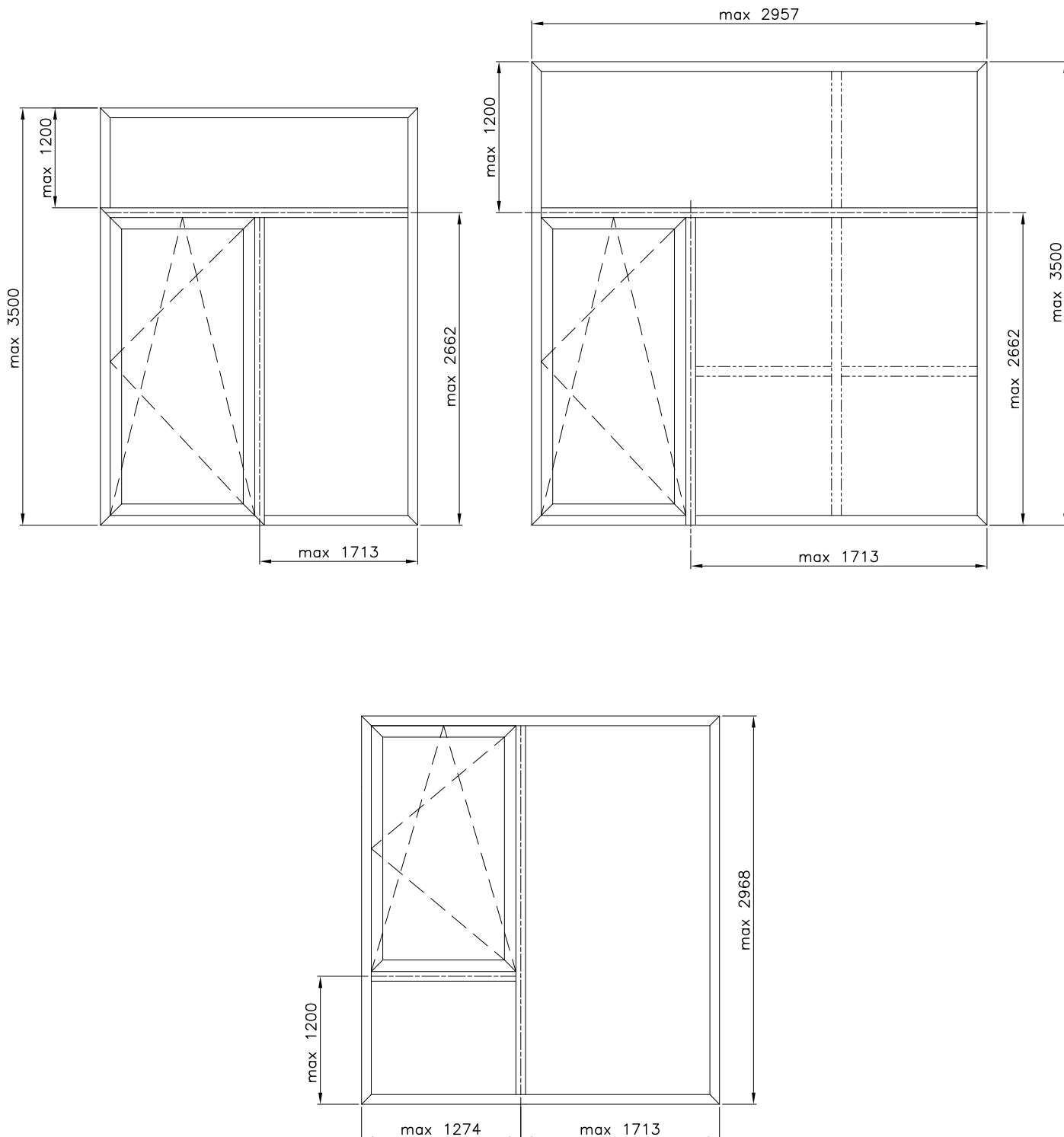

! Maksymalne wymiary szyb konsultować z dostawcą szyb.
The maximum dimensions of the glass panes please consult with the glass supplier.
Максимальные размеры стекол согласовывать с поставщиком стекол.
Die maximale Glasmasse nach der Abstimmung mit dem Glashersteller.

MB-86EI

Okna MB-86EI w ścianie profilowej MB-86EI

Windows MB-86EI in partition wall MB-86EI

Окна MB-86 EI в профильной стене MB-86 EI

MB-86 EI Fenster in der Profilwand MB-86 EI

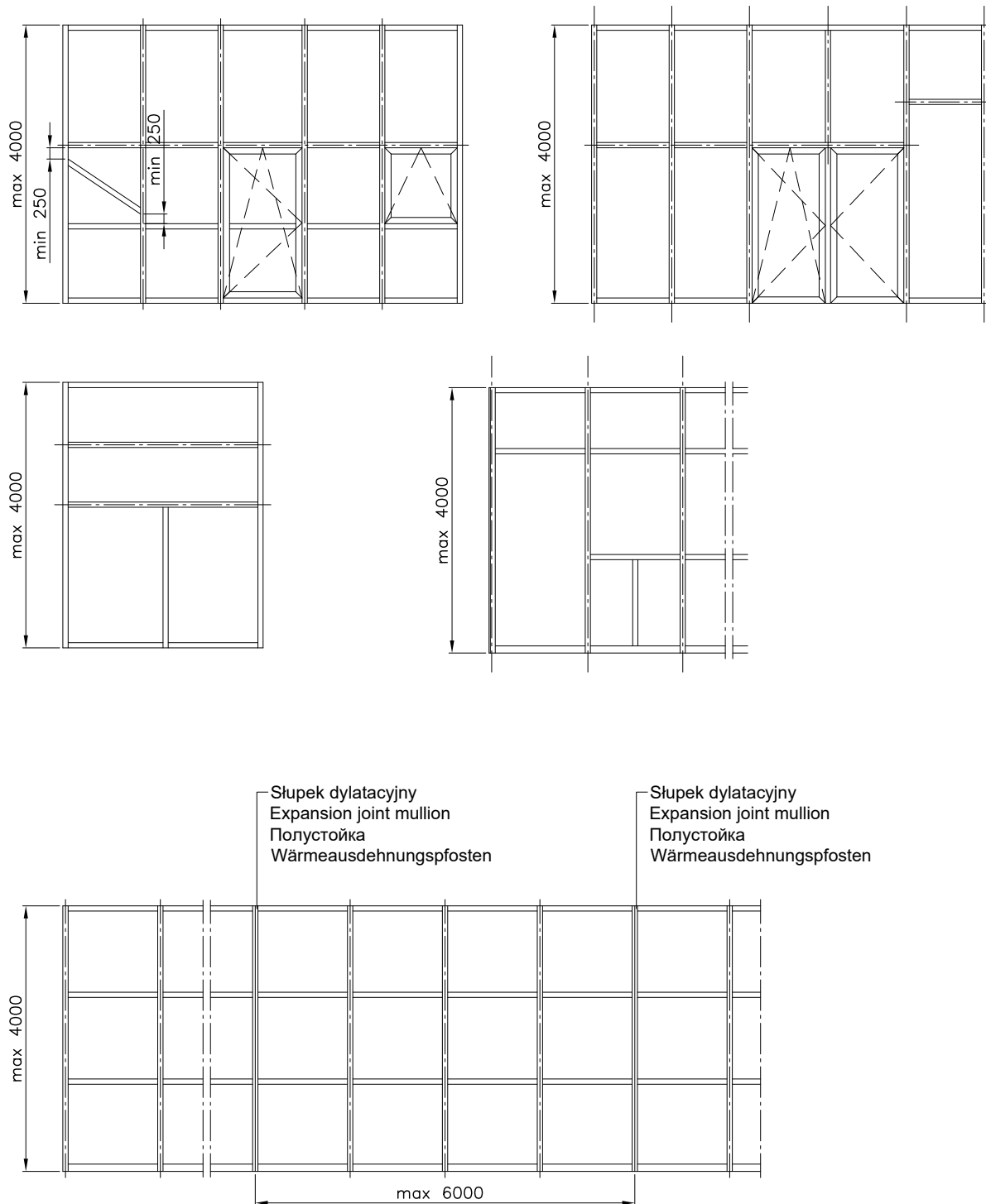

Maksymalne wymiary szyb konsultować z dostawcą szyb.

The maximum dimensions of the glass panes please consult with the glass supplier.

Максимальные размеры стекол согласовывать с поставщиком стекол.

Die maximale Glasmasse nach der Abstimmung mit dem Glashersteller.

MB-86EI

Dopuszczone układy dla okien wg normy PN-EN 15269-5+A1

Approved layouts for windows in accordance with the standard PN-EN 15269-5+A1

Утвержденные системы для окон в соот. со стандартом PN-EN 15269-5+A1

Zugelassene Layouts für Fenster gemäß Norm PN-EN 15269-5+A1

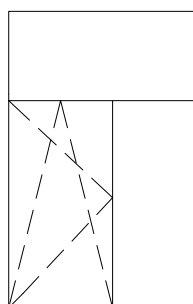

1

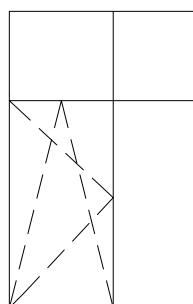

2

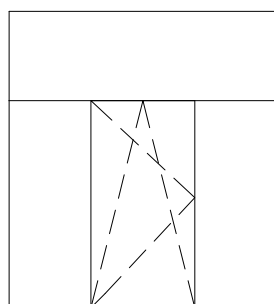

3

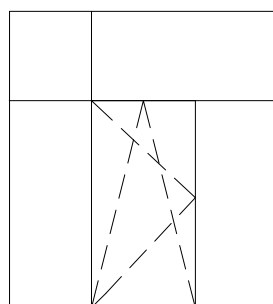

4

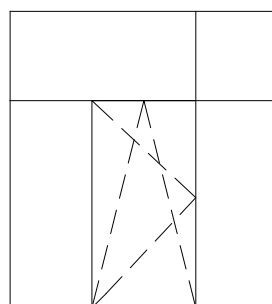

5

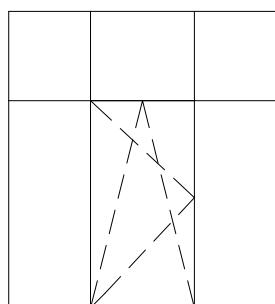

6

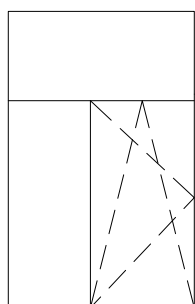

7

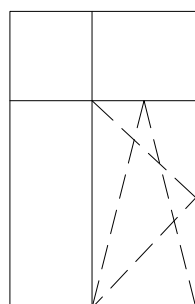

8



9

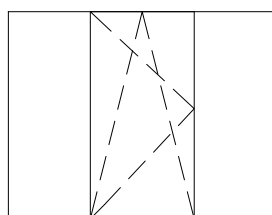

10

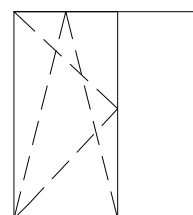

11

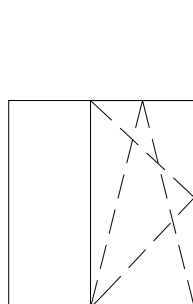

12

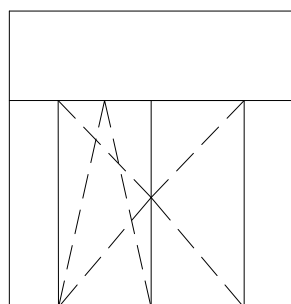

13

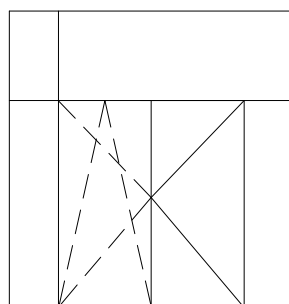

14

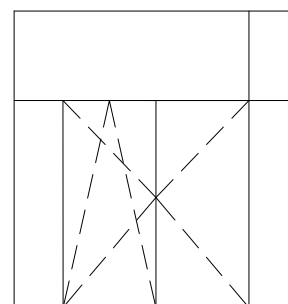

15

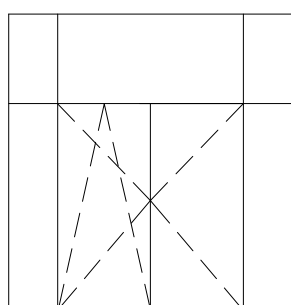

16

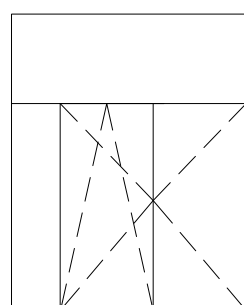

17

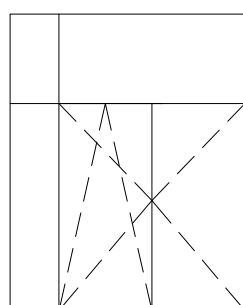

18

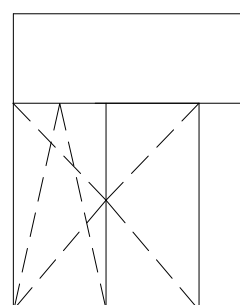

19

! Maksymalne wymiary szyb konsultować z dostawcą szyb.
The maximum dimensions of the glass panes please consult with the glass supplier.
Максимальные размеры стекол согласовывать с поставщиком стекол.
Die maximale Glasmasse nach der Abstimmung mit dem Glashersteller.

MB-86EI

Dopuszczone układy dla okien wg normy PN-EN 15269-5+A1

Approved layouts for windows in accordance with the standard PN-EN 15269-5+A1

Утвержденные системы для окон в соот. со стандартом PN-EN 15269-5+A1

Zugelassene Layouts für Fenster gemäß Norm PN-EN 15269-5+A1

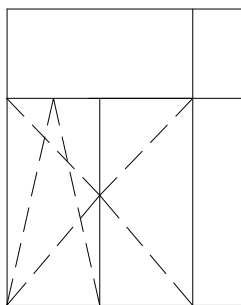

20

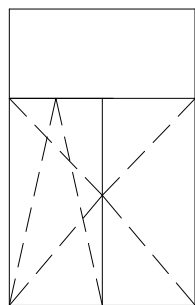

21

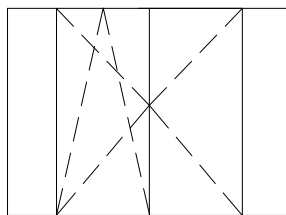

22

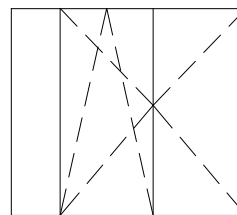

23

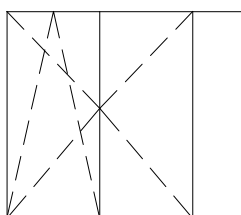

24

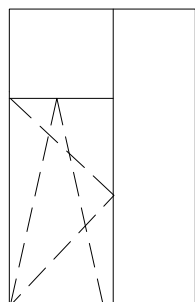

25

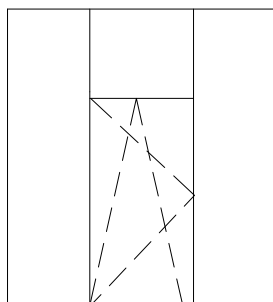

26

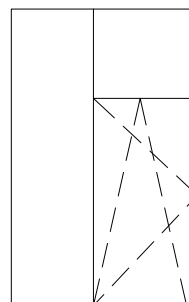

27

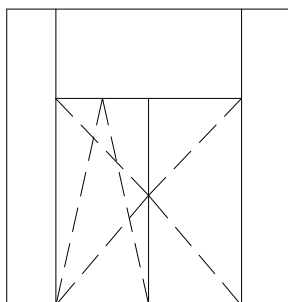

28

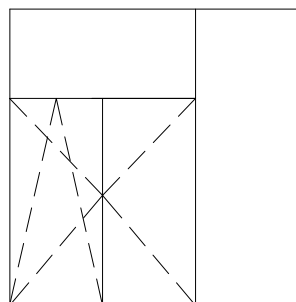

29



Maksymalne wymiary szyb konsultować z dostawcą szyb.

The maximum dimensions of the glass panes please consult with the glass supplier.

Максимальные размеры стекол согласовывать с поставщиком стекол.

Die maximale Glasmasse nach der Abstimmung mit dem Glashersteller.

MB-86EI

Maksymalne wymiary skrzydeł drzwi

Maximum dimensions of leaves

Максимальные размеры створок, подбор дверей

Maximale Abmessungen für Türflügel

Wymiary maksymalne mają ścisły związek z profilami, z których wykonane są skrzydła i obowiązują jedynie z kompletnymi zestawami okuć oraz po skojarzeniu ich z zakresem stosowania tych okuć przedstawionym w rozdziale "Okucia" i katalogu "Okucia"
Maximum dimensions are closely correlated with the profiles of which the sashes are made and they are applicable only with complete sets of hardware and they are subject to the application range of this hardware, presented in the section "Hardware" and "Hardware" catalogue
Максимальные размеры тесно связаны с профилями, из которых выполнены створки и обязательны только с полными наборами фурнитуры, а также после сочетания их с пределом применения этой фурнитуры, представленным во главе "Фурнитура".
Maximale Maße stehen im engen Zusammenhang mit Flügelprofilen und gelten ausschließlich mit kompletten Beschlägen sowie ihrem Einsatzbereich (siehe Kapitel „Beschläge“ und Katalog „Beschläge“)

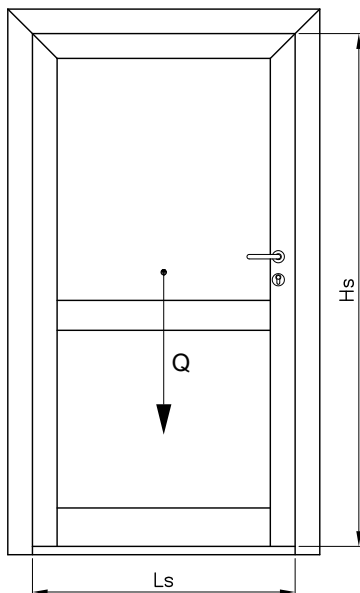

Nº	Ls max [mm]	Hs max [mm]	Q max [kg]
K(..)18744X	1300	2500	140
K(..)18745X*	1200	2400	140
K(..)18746X	1300	2500	140
K(..)18747X*	1200	2400	140
K(..)18748X	1300	3000	200
K(..)18749X*	1200	2500	200
K(..)18750X	1300	3000	200
K(..)18751X*	1200	2500	200



* Profile dylatacyjne
Expansion joint profiles
Профили дилатационные
Dehnungsprofile



Minimalne wymiary drzwi należy dobierać biorąc pod uwagę aktualne zalecenia przepisów i norm.

Adjust minimum dimensions of door taking into account current regulations and standards

Минимальные размеры дверей следует подбирать учитывая актуальные рекомендации положений и стандартов.

Minimale Türabmessungen haben den geltenden Vorschriften und Normen zu entsprechen.

MB-86EI

EI 30 Maksymalne wymiary drzwi

EI 30 Maximum dimensions of door

EI 30 Максимальные размеры дверей

EI 30 Maximale Abmessungen der Tür

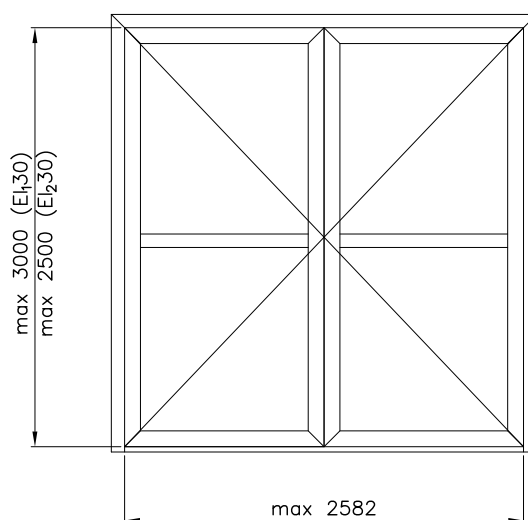
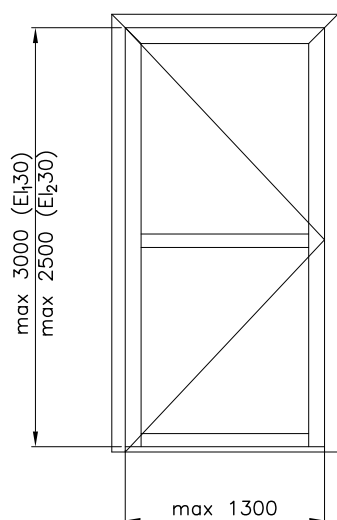
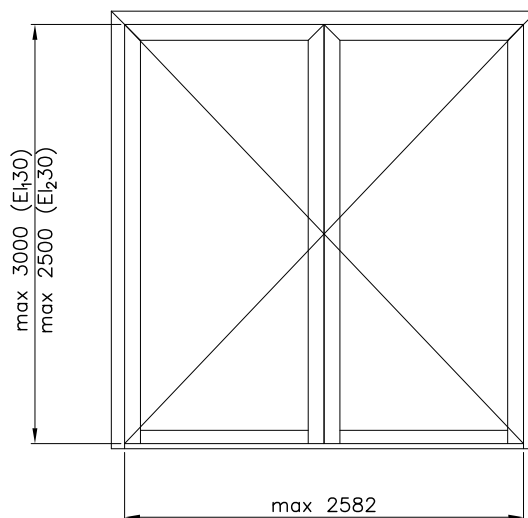
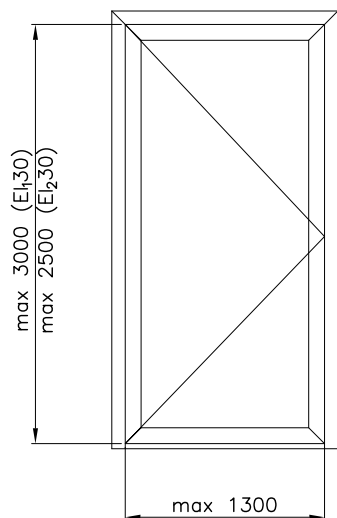

Maksymalne wymiary szyb konsultować z dostawcą szyb.

The maximum dimensions of the glass panes please consult with the glass supplier.

Максимальные размеры стекол согласовывать с поставщиком стекол.

Die maximale Glasmasse nach der Abstimmung mit dem Glashersteller.

MB-86EI

EI 30 Maksymalne wymiary drzwi

EI 30 Maximum dimensions of door

EI 30 Максимальные размеры дверь

EI 30 Maximale Abmessungen der Tür

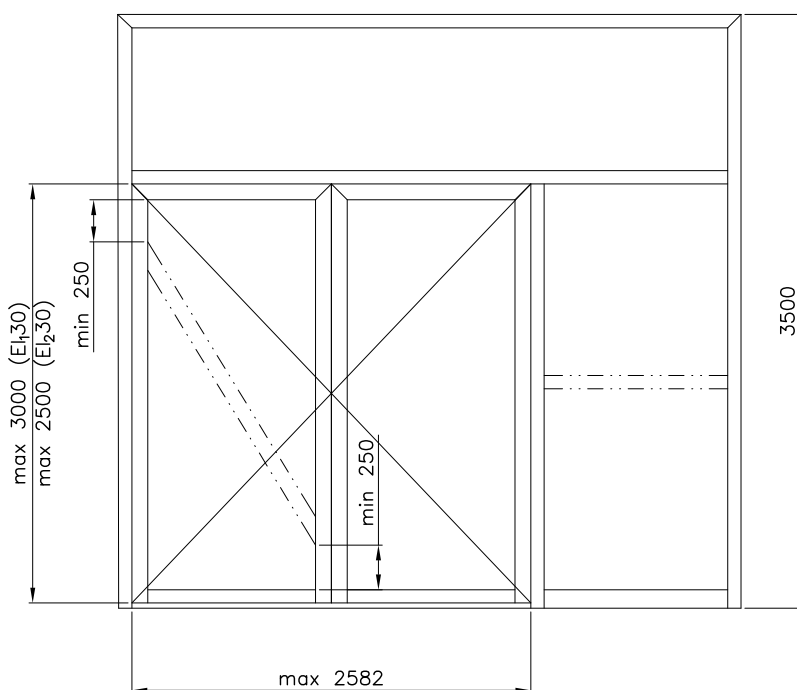
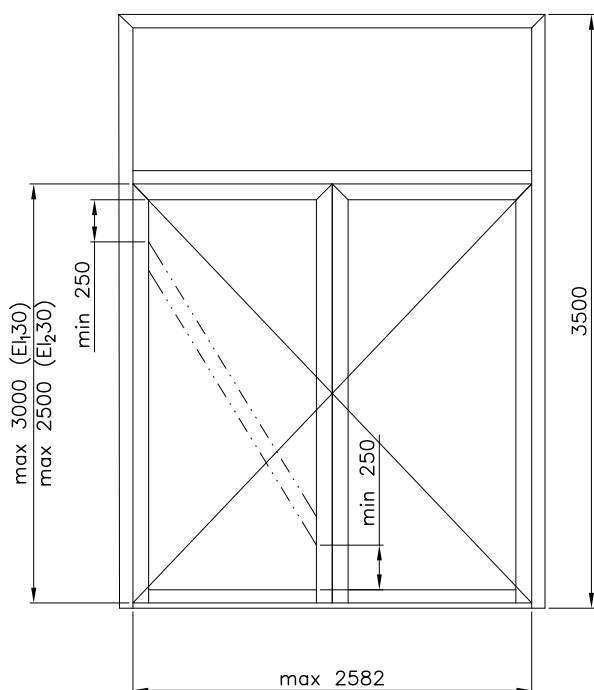
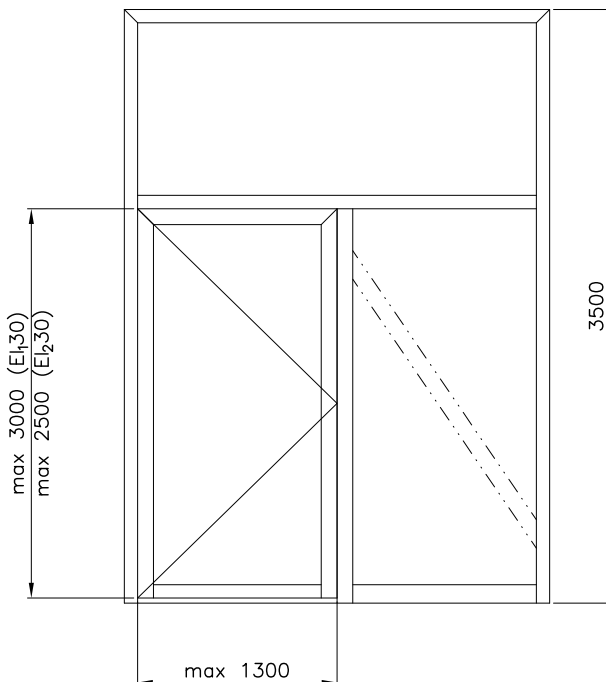
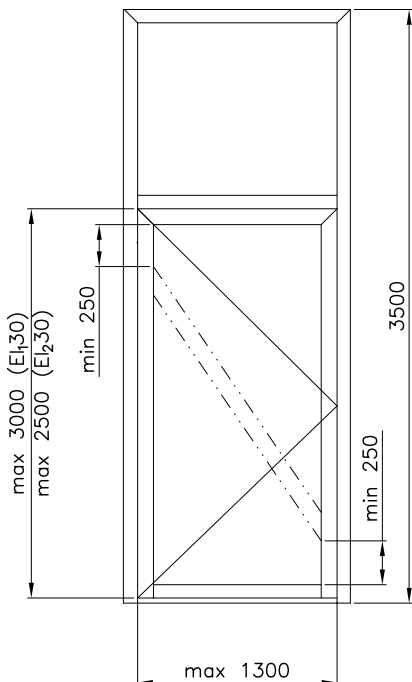

! Maksymalne wymiary szyb konsultować z dostawcą szyb.
The maximum dimensions of the glass panes please consult with the glass supplier.
Максимальные размеры стекол согласовывать с поставщиком стекол.
Die maximale Glasmasse nach der Abstimmung mit dem Glashersteller.

MB-86EI

Drzwi MB-86EI w ścianie profilowej MB-86EI

Doors MB-86EI in partition wall MB-86EI

Дверь MB-86 EI в профильной стене MB-86 EI

MB-86 EI Tür in der Profilwand MB-86 EI

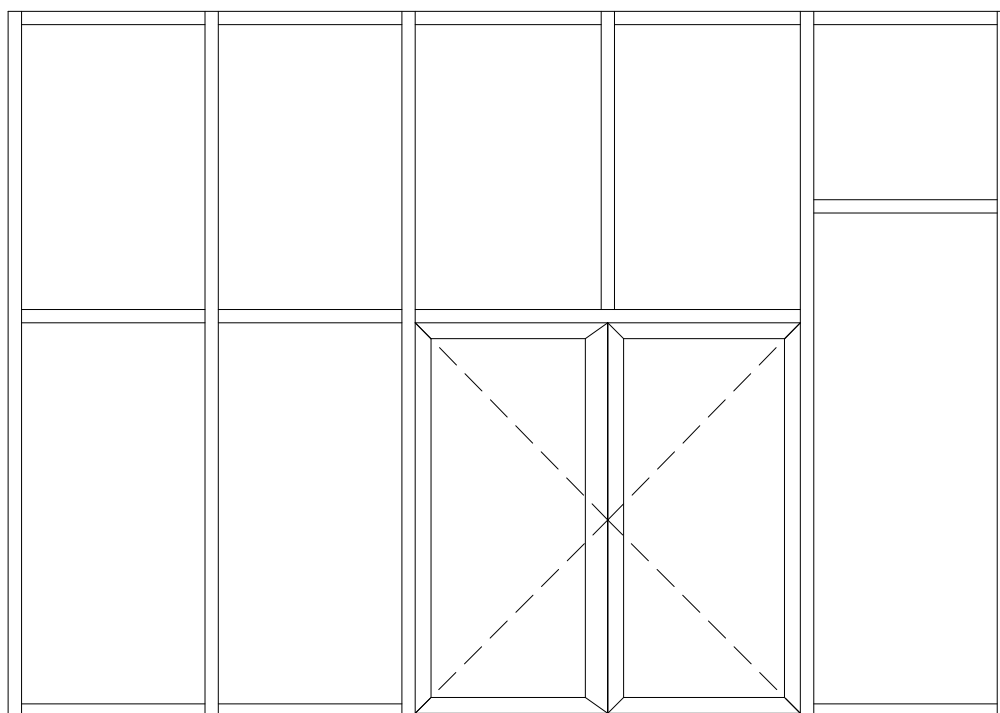
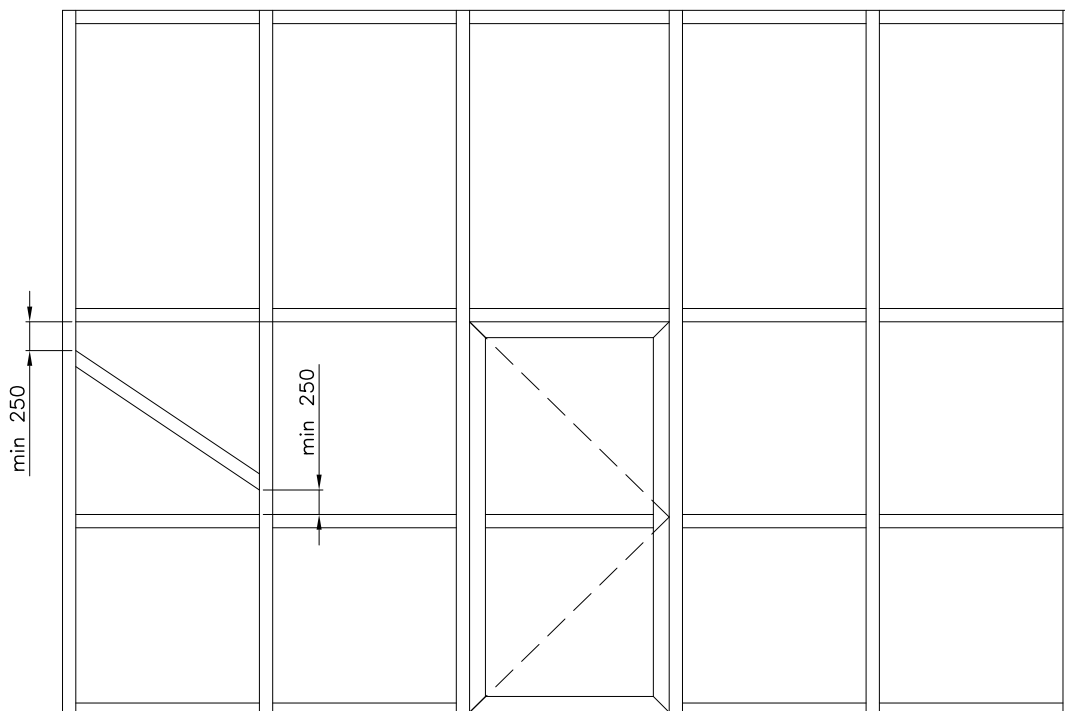

Maksymalne wymiary szyb konsultować z dostawcą szyb.

The maximum dimensions of the glass panes please consult with the glass supplier.

Максимальные размеры стекол согласовывать с поставщиком стекол.

Die maximale Glasmasse nach der Abstimmung mit dem Glashersteller.

MB-86EI

Dopuszczone układy dla drzwi wg normy PN-EN 15269-5+A1

Approved layouts for doors in accordance with the standard PN-EN 15269-5+A1

Утвержденные системы для дверей в соот. со стандартом PN-EN 15269-5+A1

Zugelassene Layouts für Tür gemäß Norm PN-EN 15269-5+A1

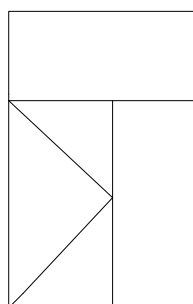

1

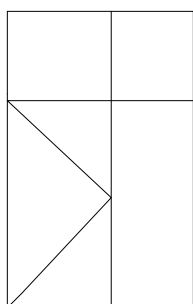

2

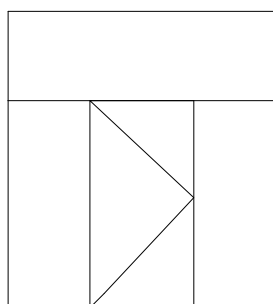

3

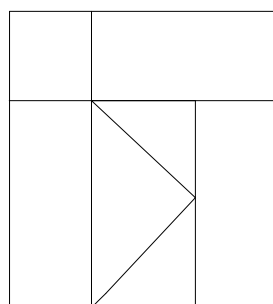

4

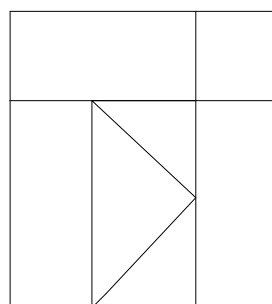

5

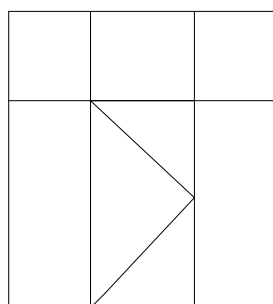

6

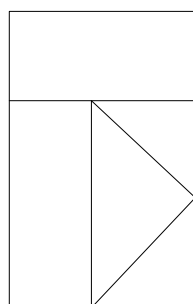

7

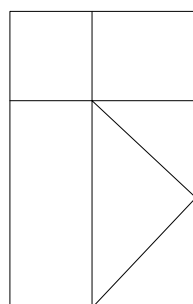

8

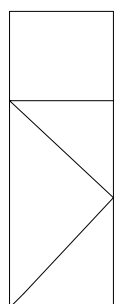

9

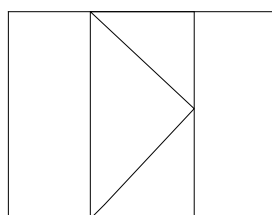

10

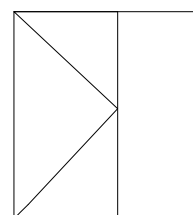

11

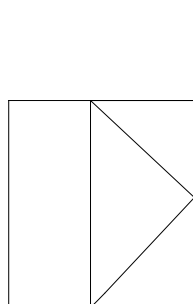

12

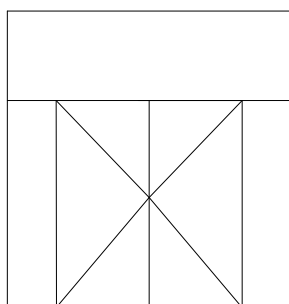

13

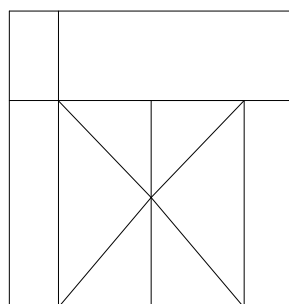

14

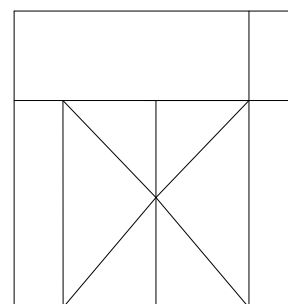

15

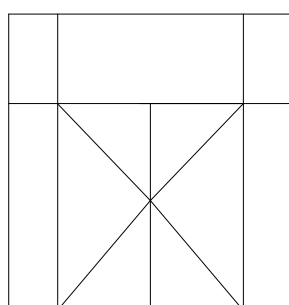

16

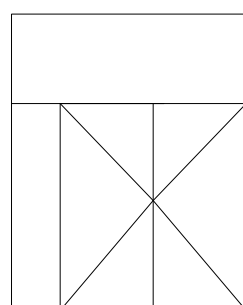

17

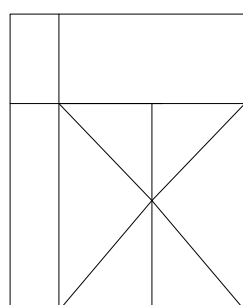

18

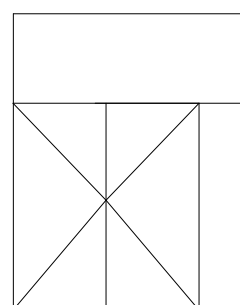

19

! Maksymalne wymiary szyb konsultować z dostawcą szyb.
The maximum dimensions of the glass panes please consult with the glass supplier.
Максимальные размеры стекол согласовывать с поставщиком стекол.
Die maximale Glasmasse nach der Abstimmung mit dem Glashersteller.

MB-86EI

Dopuszczone układy dla drzwi wg normy PN-EN 15269-5+A1

Approved layouts for doors in accordance with the standard PN-EN 15269-5+A1

Утвержденные системы для дверей в соот. со стандартом PN-EN 15269-5+A1

Zugelassene Layouts für Tür gemäß Norm PN-EN 15269-5+A1

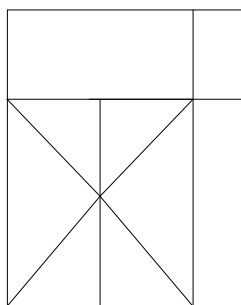

20

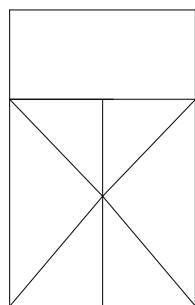

21

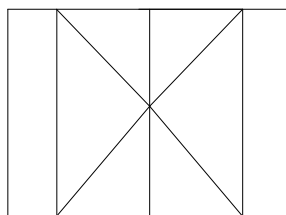

22

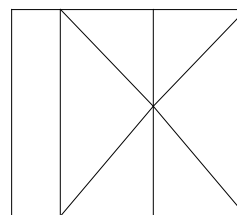

23

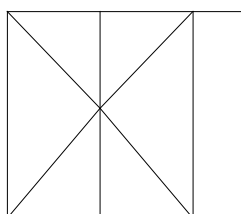

24

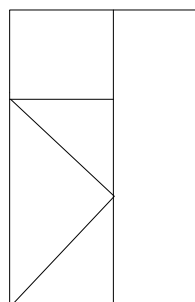

25

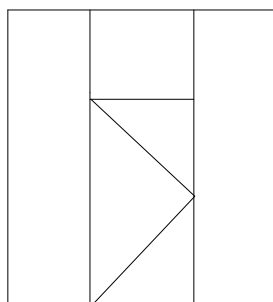

26

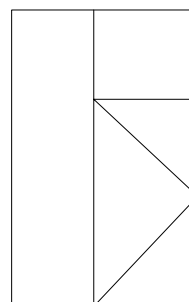

27

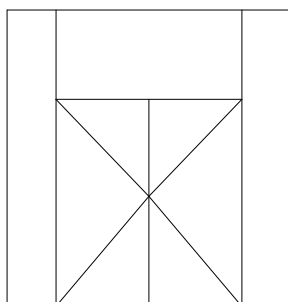

28

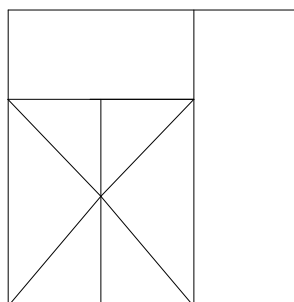

29



Maksymalne wymiary szyb konsultować z dostawcą szyb.

The maximum dimensions of the glass panes please consult with the glass supplier.

Максимальные размеры стекол согласовывать с поставщиком стекол.

Die maximale Glasmasse nach der Abstimmung mit dem Glashersteller.