

**INDEKS MATERIAŁOWY**  
**MATERIAL INDEX**  
**УКАЗАТЕЛЬ МАТЕРИАЛОВ**  
**MATERIAL-INDEX**



Kształtowniki / Profiles / Профили / Profile

Article number	Name	Page	
		Overview	Application
K417914X		04-0-03.00	07-1-15.00
K417915X	Spacing covering strip 10mm	04-0-03.00	07-1-06.00
K417916X	Spacing covering strip 20mm	04-0-03.00	07-2-06.00
K417917X	Spacing covering strip 30mm	04-0-03.00	
K417961X	Angular connecting member	04-0-01.00	09-2-41.00
K4304180	Gasket ends fitting	04-0-03.00	09-2-17.00
K430475X	Mullion reinforcement 49mm	04-0-01.00	09-2-10.00
K430476X	Mullion reinforcement 69mm	04-0-01.00	09-2-10.00
K430477X	Mullion reinforcement 89mm	04-0-01.00	09-2-10.00
K430482X	Mullion 85mm	04-0-01.00	09-2-04.00
K430483X	Mullion 105mm	04-0-01.00	09-2-04.00
K430484X	Mullion 125mm	04-0-01.00	09-2-04.00
K430491X	Transom 89,5mm	04-0-02.00	09-2-05.00
K430492X	Transom 109,5mm	04-0-02.00	09-2-05.00
K430493X	Transom 129,5mm	04-0-02.00	09-2-05.00
K431525X	Mullion 145mm	04-0-01.00	09-2-04.00
K431526X	Mullion 165mm	04-0-01.00	09-2-04.00
K431527X	Mullion 185mm	04-0-01.00	09-2-04.00
K431528X	Mullion 205mm	04-0-01.00	09-2-04.00
K431529X	Mullion 225mm	04-0-01.00	09-2-04.00
K431531X	Transom 149,5mm	04-0-02.00	09-2-05.00
K431532X	Transom 169,5mm	04-0-02.00	09-2-05.00
K431533X	Transom 189,5mm	04-0-02.00	09-2-05.00
K431543X	Transom 69,5mm	04-0-02.00	09-2-05.00
K431593X	Mullion 85mm	04-0-01.00	09-2-04.00
K431594X	Mullion 105mm	04-0-01.00	09-2-04.00
K431595X	Mullion 125mm	04-0-01.00	09-2-04.00
K431596X	Mullion 145mm	04-0-01.00	09-2-04.00
K432145X	Mullion reinforcement	04-0-01.00	09-2-06.00
K432146X	Mullion reinforcement	04-0-01.00	09-2-06.00
K432147X	Mullion reinforcement	04-0-01.00	09-2-06.00
K432148X	Mullion reinforcement	04-0-01.00	09-2-06.00
K432149X	Mullion reinforcement	04-0-01.00	09-2-06.00
K432152X	Transom 69,5mm	04-0-02.00	09-2-05.00
K432153X	Transom 89,5mm	04-0-02.00	09-2-05.00
K432154X	Transom 109,5mm	04-0-02.00	09-2-05.00
K432155X	Transom 129,5mm	04-0-02.00	09-2-05.00
K432156X	Transom 149,5mm	04-0-02.00	09-2-05.00
K432157X	Transom 169,5mm	04-0-02.00	09-2-05.00
K432158X	Transom 189,5mm	04-0-02.00	09-2-05.00
K433143X	Spacing covering strip 25mm	04-0-03.00	



Akcesoria / Accessories / Комплектующие / Zubehör

Article number	Name	Page	
		Overview	Application
009013	Thermal insulator 13mm	05-0-02.00	07-1-01.00
009020	Thermal insulator 8mm	05-0-02.00	08-0-07.00
009021	Thermal insulator 17mm	05-0-02.00	08-0-04.00
009022	Thermal insulator 21mm	05-0-02.00	07-2-01.00
009060	Thermal insulator 25mm	05-0-02.00	08-0-06.00
009083	Thermal insulator 12mm	05-0-02.00	09-2-29.00
120557	Sealing cord $\phi$ 4mm	05-0-01.00	07-1-11.00
120562	End gasket	05-0-01.00	07-1-11.00
120615	Transom sealing	05-0-03.00	07-1-22.00
120655	Swelling tape 22 mm	05-0-01.00	09-2-30.00
120900	Gasket 4mm	05-0-01.00	08-0-01.00
120901	Gasket 5mm	05-0-01.00	07-2-22.00
120902	Gasket 6mm	05-0-01.00	07-1-02.00
120903	Gasket 7mm	05-0-01.00	08-0-01.00
120904	Gasket 8mm	05-0-01.00	08-0-01.00
120905	Gasket 9mm	05-0-01.00	08-0-01.00
120906	Gasket 10mm	05-0-01.00	07-2-01.00
120907	Gasket 11mm	05-0-01.00	07-1-01.00
120908	Gasket 12mm	05-0-01.00	08-0-01.00
120909	Gasket 13mm	05-0-01.00	08-0-01.00
120937	Covering gasket	05-0-03.00	09-2-37.00
120963	Covering gasket	05-0-03.00	09-2-37.00
121160	Covering gasket	05-0-03.00	
121161	Covering gasket	05-0-03.00	
121162	Covering gasket	05-0-03.00	
121163	Covering gasket	05-0-03.00	
127108	Swelling tape 32 mm	05-0-01.00	07-2-01.00
127109	Swelling tape 42 mm	05-0-01.00	08-0-06.00
127111	Gasket 26x2mm	05-0-02.00	07-1-01.00
127112	Gasket 26x 6mm	05-0-02.00	07-1-01.00
127113	Gasket 26x10mm	05-0-02.00	08-0-04.00
12894900	Cleaning agent Coralclean	05-0-13.00	05-0-13.00
12894920	Remover DC R-40	05-0-13.00	05-0-13.00
13364617	Single-component quick-bonding glue	05-0-13.00	05-0-13.00
14614947	Silicone DC791	05-0-13.00	05-0-13.00
14614959	Fireproof caulk	05-0-13.00	05-0-13.00
14614967	Fire-resistant silicone	05-0-13.00	05-0-13.00
80002051	Fixed hardware 3D	05-0-12.00	09-4-03.00
80002052	Active hardware 3D	05-0-12.00	09-4-03.00
80002121	Fixed hardware 2D	05-0-11.00	09-4-02.00
80002122	Active hardware 2D	05-0-11.00	09-4-02.00
80002123	Fixed hardware 2D	05-0-10.00	09-4-05.00
80002124	Active hardware 2D	05-0-10.00	09-4-05.00
80122119	Connecting member	05-0-08.00	09-2-39.00
80311079	Mullion-mullion sealing	05-0-03.00	09-1-06.00
80312107	Stell pivot $\phi$ 10xM6x55	05-0-08.00	07-2-22.00
80312116	Glazing bracket 42mm	05-0-05.00	08-0-01.00
80312117	Glazing bracket 46mm	05-0-05.00	08-0-01.00
80312118	Glazing bracket 50mm	05-0-05.00	08-0-01.00
80312119	Glazing bracket 54mm	05-0-05.00	08-0-02.00
80312120	Glazing bracket 58mm	05-0-05.00	08-0-02.00

Akcesoria / Accessories / Комплектующие / Zubehör

Article number	Name	Page	
		Overview	Application
80312121	Glazing bracket 62mm	05-0-05.00	08-0-02.00
80312122	Glazing bracket 66mm	05-0-05.00	08-0-03.00
80322170	Mounting plate, two-sided	05-0-09.00	08-0-04.00
80322171	Mounting plate, one-sided	05-0-09.00	08-0-04.00
80322172	Mounting plate, two-sided	05-0-09.00	08-0-04.00
80322173	Mounting plate, one-sided	05-0-09.00	08-0-04.00
80328047	Mechanical protection	05-0-03.00	09-3-15.00
80341031	U profile 100mm	05-0-09.00	07-1-22.00
80371208	Screw 3,9x13mm	05-0-07.00	09-2-35.00
80371255	Bolt M8x25	05-0-08.00	09-2-41.00
80371256	Bolt M6x35	05-0-07.00	07-1-22.00
80371260	Bolt M6x12	05-0-08.00	09-2-39.00
80371275	Bolt M6x70	05-0-08.00	09-2-39.00
80371336	Bolt M6x16	05-0-07.00	07-2-22.00
80371386	Bolt M6x50	05-0-07.00	07-1-22.00
80371389	Bolt M6x55	05-0-07.00	07-2-22.00
80371390	Bolt M6x60	05-0-07.00	08-0-06.00
80371391	Bolt M6x65	05-0-07.00	07-1-22.00
80371392	Bolt M6x70	05-0-07.00	08-0-04.00
80371393	Bolt M6x75	05-0-07.00	08-0-05.00
80371394	Bolt M6x80	05-0-07.00	08-0-06.00
80375311	Washer M10	05-0-08.00	09-2-41.00
80375312	Nut M6	05-0-08.00	09-2-41.00
80375322	Washer M6	05-0-08.00	09-2-39.00
80376019	Spring pin 5x30mm	05-0-08.00	09-2-41.00
80376051	Stell pivot for mullion-transom joint - $\phi$ 11x50	05-0-08.00	09-2-02.00
80376052	Stell pivot for mullion-transom joint - $\phi$ 11x100	05-0-08.00	07-1-22.00
80462154	Insulating insert Promat 6x44x2600	05-0-04.00	04-0-07.00
80462156	Insulating insert CI 10x24x2000	05-0-04.00	09-2-23.00
80462157	Insulating insert CI 10x44x2000	05-0-04.00	07-2-22.00
80462158	Insulating insert CI 10x64x2000	05-0-04.00	07-2-22.00
80462159	Insulating insert GKF 12,5x44x2600	05-0-04.00	07-1-22.00
80462160	Insulating insert GKF 12,5x64x2600	05-0-04.00	07-1-22.00
80462161	Insulating insert GKF 12,5x84x2600	05-0-04.00	09-2-25.00
80462164	Insulating insert CI 10x84x2000	05-0-04.00	09-2-25.00
80462202	Mullion drainage insert	05-0-03.00	09-1-07.00
80490036	Drainage profile	05-0-03.00	09-1-07.00
80490171	Drainage profile	05-0-03.00	
80957052	Glazing washer, hard Wood 1x36x100	05-0-06.00	08-0-01.00
80957053	Glazing washer, hard Wood 1x40x100	05-0-06.00	08-0-01.00
80957054	Glazing washer, hard Wood 1x44x100	05-0-06.00	08-0-01.00
80957055	Glazing washer, hard Wood 1x48x100	05-0-06.00	08-0-02.00
80957056	Glazing washer, hard Wood 1x52x100	05-0-06.00	08-0-02.00
80957057	Glazing washer, hard Wood 1x56x100	05-0-06.00	08-0-02.00
80957058	Glazing washer, hard Wood 1x60x100	05-0-06.00	08-0-03.00
80957065	Glazing washer, hard Wood 3x36x100	05-0-06.00	08-0-01.00
80957066	Glazing washer, hard Wood 3x40x100	05-0-06.00	08-0-01.00
80957067	Glazing washer, hard Wood 3x44x100	05-0-06.00	08-0-01.00
80957068	Glazing washer, hard Wood 3x48x100	05-0-06.00	08-0-02.00
80957069	Glazing washer, hard Wood 3x52x100	05-0-06.00	08-0-02.00
80957070	Glazing washer, hard Wood 3x56x100	05-0-06.00	08-0-02.00

Akcesoria / Accessories / Комплектующие / Zubehör

Article number	Name	Page	
		Overview	Application
80957071	Glazing washer, hard Wood 3x60x100	05-0-06.00	08-0-03.00
87222206	Screw 3,5x22mm	05-0-07.00	09-2-27.00
87252203	Screw 3,5x13mm	05-0-07.00	07-1-11.00
87252609	Screw 5,5x38mm	05-0-07.00	09-2-19.00
87252610	Screw 5,5x45mm	05-0-07.00	09-2-19.00
87252611	Screw 5,5x50mm	05-0-07.00	09-2-19.00
87252722	Screw 5,5x19mm	05-0-07.00	09-2-18.00



Oprzrządowanie / Tooling / Оснащение / Werkzeugausrüstung

Article number	Name	Page	
		Overview	Application
B5F-005-00	Countersink bit	06-0-06.00	09-2-13.00
F6K-015-00	Countersink bit	06-0-06.00	
P9K-819-00	Tool to bore holes in transom	06-0-03.00	09-2-13.00
P9K-823-00	Toll to remove strip	06-0-04.00	
P9K-826-00	Tool to bore holes in mullion	06-0-02.00	09-2-15.00
P9K-944-00	Tool to bore holes in mullion	06-0-01.00	09-2-10.00
P9K-945-00	Boring jig	06-0-05.00	09-2-12.00
T1K-702-01	Multi-purpose blanking die	06-0-07.00	
T1K-703-00	Multi-purpose blanking die	06-0-08.00	



**OPIS TECHNICZNY**  
**TECHNICAL DESCRIPTION**  
**ТЕХНИЧЕСКОЕ ОПИСАНИЕ**  
**TECHNISCHE BESCHREIBUNG**



## **MB-SR50N EI EFEKT MULLION-TRANSOM WALL SYSTEM**

### **1. TECHNICAL DESCRIPTION OF THE SYSTEM**

#### **1.1 Structural features**

The mullion-transom system MB-SR50N EI EFEKT is intended for the construction and execution of light fire resistant curtain and filling walls of the fire resistance class EI15, EI30, EI45, EI60 according to the standards PN-EN 1364-3 and PN-EN 1364-1. The system has been classified as non-fire-propagating (NFP).

Due to the application of a special system of fitting glass panels to mullions and transoms, a smooth surface is obtained on the outside, divided by a grid of vertical and horizontal lines 24 mm wide. The façade executed in this system ensures excellent performance characteristics and thanks to the possibility of application of two-chamber glazing - very high thermal insulation performance is achieved, which is, in view of the world-wide trend oriented towards reduction in energy consumption, one of the fundamental criteria of assessment of curtain walls. A load bearing structure consists of vertical (mullions) and horizontal (transoms) aluminium profiles of box section, appropriately joined with each other and accessories with the function of sealing and connecting. The assortment of transoms falls into two groups of profiles (1 & 2) featuring different resistance parameters. Load-bearing profiles, which are flush on the inside of the façade feature fixed width of 50mm. The façade is mounted onto the building by means of a system of consoles, meeting the intended use and featuring appropriate load capacity.

In order to obtain fireproof aluminium profiles, mullions and transoms have been equipped with special fireproof inserts. A fireproof insert consists of a special-shape aluminium profile, fulfilling the function of reinforcement, shielded with panels made from fireproof materials.

This design of the construction made it possible to admit to the system standard profiles of mullions and transoms applied in the MB-SR50N system, which significantly enhanced cost efficiency of the whole construction and ensured identical appearance to the profiles of the MB-SR50N system.

The MB SR50N EI EFEKT construction utilizes mullions ranging from 85÷225mm in depth and transoms whose depth is between 69,5÷189,5mm.

The system provides for a possibility of overlapping connection between transom and mullion, which enables efficient water deflection and proper ventilation of inter-pane space.

In order to achieve optimal thermal and acoustic insulation performance there has been applied a continuous thermal break (insulator) made of material called "HPVC" and profiled EPDM glazing gaskets. Glass panels or other infills are fitted in glazing grooves, shaped from mullion and transom profiles and. Additionally, a special expanding tape has been applied in glazing grooves of mullions and transoms. Such system of glazing protects a fireproof glass panel or other infills from falling off from the frame during fire. In the case of an angular wall special gaskets have been applied.

Fixed glazing and non-transparent infills are mechanically fitted pointwise to the load bearing structure through special clamping plates. Both the layout of fixation points and the structure of the infill should be determined on an individual basis for a particular project. The catalogue presents examples of the standard layout of fixation points and the structure of the infill.

Glass panels applied in the EFEKT system are special single-chamber or double-chamber sets within the glazing range 36-64 mm of different, defined configuration, meeting the requirements of the standard PN-EN 12150-1, PN-EN 1279-1:2006 and PN-EN 1279-5:2006. The panes are sealed by means of special silicone structural sealant, which protects the pane against tearing and unsealing of the joint, which could lead to detachment of the infill from the aluminium structure. Sealing is performed as a factory, strictly supervised process, which ensures the appropriateness of the joint. If required, e.g. under local regulations, the system provides for mounting additional mechanical elements protecting the pane against falling out. There are special elements along the perimeter of the pane enabling fastening of clamping plates, screwed onto mullions and transoms. Having regard for resistance, a risk of glass breaking on account of temperature changes and safety of users tempered (thermally toughened) glass is recommended.

The wall of the MB SR50N EI EFEKT system should be executed in accordance with working design, prepared individually for each object. Subject to the system documentation and structural analysis, the design should specify aluminium profiles for mullions and transoms, accessories to fasten mullions to the structure of the building and transoms to mullions, a lay-out of points where the construction of the wall is to be fixed to the building construction.

The design should also take into account all other materials and elements of the wall, details of connections and sealing between wall elements and the building construction, ventilating method and drainage of the wall. While

taking into account requirements connected with the function and location and geometry of the building, the wall should be designed in accordance with applicable standards.

Allowable height of a curtain wall is a derivative of resistance-related parameters, ensuing from the structural analysis. However, at every floor the structure should be divided with vertical thermal expansion joints. Allowable spacing and span of load-bearing profiles, based on assumed structural analysis diagram result from structural analysis of construction and dimensions of infills. The curtain wall is in no way restricted as to its length, providing the horizontal expansion joint has been applied.

To ensure proper performance of the structure, it is necessary to perform expansion joints, whose main purpose is compensation of horizontal and vertical movements of the façade, caused by thermal expansion of aluminium profiles and deformations of the load-bearing structure of the building onto which the façade is mounted.

To maintain the appropriate usable properties the wall is sealed from the outside with a special polyethylene insulating cord PE (PP) and weather silicone, ensuring tightness of the seal to rain water infiltration and air penetration and guarantees excellent thermal insulation performance of the façade.

The MB-SR50N EFEKT system is compatible with other systems fabricated by ALUPROF, such as external doors.

## 1.2 Profile dimensions

- characteristic width of mullions and transoms - 50 mm
- depth of mullions 85 - 225 mm
- depth of transoms 69,5 – 189.5 mm

## 1.3 General overview of resistance parameters of mullion and transoms

	$I_x$ [cm <sup>4</sup> ]		$I_y$ [cm <sup>4</sup> ]		$I_z$ [cm <sup>4</sup> ]	
	min	max	min	max	min	max
Mullions	83,80	1222,14	23,74	81,35	-	-
Transoms	-	-	20,81	66.60	48,07	629.54

1.4 Thermal insulation of sections  $U_f$  should be calculated according to EN ISO 10077-2 or there can be used the  $U_f$  values laid down in valid test reports.

1.5 Air permeability – AE 1200 (standard: EN 12152)

1.6 Watertightness – RE 1200 (standard: EN 12154)

1.7 Resistance to wind load – 2.4 kN/m<sup>2</sup> (standard: EN 13116)

1.8 Impact resistance – class I5/E5 (standard: EN 14019)

## 2. TECHNICAL DESCRIPTION OF RAW MATERIALS AND MATERIALS

### 2.1 Aluminium profiles

Aluminium profiles are produced in the process of mechanical working of the aluminium alloy:

**EN AW-6060 T66** in conformance with the following standards:

- chemical composition of alloy: EN 573-3, EN 515
- tolerances on dimensions and form of extruded precision profiles EN 12020-2
- mechanical properties: EN 755-2
- conformant to EN 755-1 [*Technical conditions for inspection and delivery of wrought aluminium and aluminium alloy extruded rod/bar, tube and profile for general engineering applications*]

Surfaces of profiles are finished with anodic oxide coatings, meeting the requirements set forth for Qualanod quality label or with Qualicaot-approved polyester powder coatings. The said coatings are applied as protection against corrosion.

### 2.2 Thermal break (insulator).

Insulators are made from HPVC. Insulating cords are made from PE

### 2.3 Fireproof materials

Fire protection elements are made of GKF plasterboards, silicate-cement panels manufactured by PROMATEC -H and panels made from CI material. There are also applied fireproof expanding tapes cut off from the panels or supplied in rolls, as well as fireproof sealants.

### 2.4 Gaskets

Glazing gaskets are made from EPDM - synthetic rubber, according to DIN 7863 and working standard as per DIN 7715 E2 or ISO 3302-1. Gaskets are joined either by gluing or vulcanizing.

### 2.5 Infills

The infill of the transparent sections of the MB-SR50N EI EFEKT curtain & infill-type wall consists of Type 1 fire-resistant double or triple glazing units that meet the requirements of the corresponding fire resistance rating of EI15, EI30, EI45, EI60.

### Recommendations

In MB-SR50N EI EFEKT, it is recommended to use tempered glass ESG for external glazing. For internal glazing, it is recommended to use fire-resistant glass.

In view of the fact that that glazing is mounted pointwise, it is absolutely necessary to carry out structural analysis with regard to the resistance of the applied pane, taking into account all external loads and safety guidelines determined for a particular object.

The MB-SR50N EI EFEKT wall can be glazed in a continuous manner with 36-64 mm-thick glass panes. Fire-resisting doors offered by ALUPROF S.A. can also be used as infills for the transparent sections

LIST OF FIRE-STOPPING GLASS PANES FOR VERTICAL APPLICATIONS **Type 1**

Poz.	Producer	Type of internal pane in a double-glazed unit	Class	Minimum thickness, mm	Maximum dimensions for the vertical rectangle (S x H)	Maximum dimensions for the horizontal rectangle (S x H)
1	2	3	4	5	6	7
1	Polflam	Polflam 20	EI30	20	1500 x 3000	2400 x 1500
2		Polflam 25	EI60	25		
3	Vetrotech (Saint-Gobain)	Contraflam 30	EI30	16	1500 x 3000	1700 x 1200
4		Contraflam 30-2	EI30	20		
5		Contraflam 60	EI60	25	1500 x 3000	1700 x 1200
6		Contraflam 60-3	EI60	27		
9	Q4Glass	Q4FIRE STOP 60	EI60	30	1500 x 3000	2000 x 1500

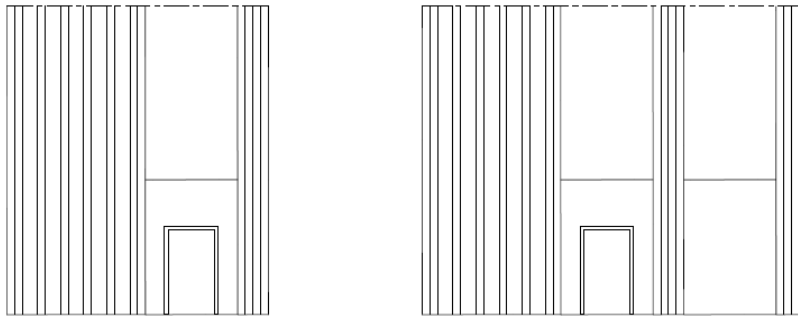

A sample drawing of vertical glass panes Type 1

**NOTE: The maximum thickness of the infill used in Aluprof MB-SR50N EI EFEKT curtain & infill-type walls is 64 mm. The maximum available glazing size should be consulted with the glazing supplier.**

The infills in horizontal spandrel panels are designed as sandwich elements in accordance with the system construction documents as stated below (seen from the outside):

- single pane, double glazing unit or panel rated at least A2-s3, d0 to PN-EN 13501-1 [2.1.2],
- air void 5 ÷ 20 mm,
- minimum 120 mm rock wool with minimum density of:
  - minimum 75 kg/m<sup>3</sup> for horizontal spandrel panels of not more than 1000 mm in height and a mullion spacing of not more than 2400 mm
  - minimum 80 kg/m<sup>3</sup> for horizontal spandrel panels of more than 1000 mm in height and a mullion spacing of more than 2400 mm
- galvanized steel sheet with a minimum thickness of 0.8 mm,
- minimum 12.5 mm-thick, single F-type plasterboard.

## 2.6 Aluminium sheets

Aluminium sheets are made from aluminium alloy PA2N as per EN 485, anodised or powder-coated and used for sandwiched elements or for sheet working and finish.

## 2.7 Steel sheets

Steel sheets are protected against corrosion with protective zinc or powder coating.

## 2.8 Mineral wool

Mineral wool applied to insulate lintel/apron areas, attics, etc., authorized for use in building industry under an applicable technical approval.

## 2.9 Fixation elements

Fixation elements (self-drive screws, self-tapping screws, bolts nuts washers) applied to make connections are made of stainless steel according to the standards referred to in the system documentation.

## 2.10 Steel brackets

Steel brackets are made from steel sheet and are protected against corrosion; points of contact between steel and aluminium elements are isolated.

## 2.11 Auxiliary materials

Auxiliary materials, e.g. adhesives and silicones in accordance with the system documentation.

## 2.12 Silicones

Weather silicones recommended for application:

- Dow Corning: DC 791 (ALUPROF 14614947)
- Sika: Sikasil WS-605 S
- Tremco: FS500

Silicones sealing EFEKT insulating glass units recommended for application:

- Dow Corning: DC 3362
- Sika: Sikasil IG-25 / Sikasil IG-25 HM Plus
- Tremco: JS562 / JS562 HD

Constructional silicones recommended for application:

- Dow Corning: DC 993
- Sika: Sikasil SG-500
- Tremco: SG200 Proglaze II



**Silicones applied in the structure should be compatible, i.e. they should come from one manufacturer. Where silicone combinations from different manufacturers are applied, compatibility testing must be carried out, or else the warranty will be null and void.**

**NOTE: Aluprof S. A. is liable for components of the system manufactured and supplied by the company (profiles, accessories, gaskets, etc.). With regard to glass panes and silicones, any instructions concerning their use, resistance and compatibility, etc. should be consulted with their manufacturer.**

### 3. SUPPLEMENTARY INFORMATION

#### 3.1 Working

Decorative surfaces of profiles should be covered with protective foil for protection from any working-related damage.

Linear and angular dimensional tolerances, disregarding individual designation of tolerance, as per EN 22768-1, Class of tolerance – m (medium accuracy level).

Any splinters which occur in the process of working should be absolutely deburred.

#### 3.2 Assembly guidelines at the building

The mullion-transom wall of the MB-SR50N EFEKT system is fastened to the construction of the building by means of special steel or aluminium brackets. Elements of brackets are screwed on to the ceiling/floor slab of the building by means of steel expansion bolts (or other bolts adjusted to a particular type of the slab). Mullions, i.e. vertical members are screwed to the bracket with fixing screws. Consoles are equipped with oblong holes, which ensure the accuracy of mullions positioning in relation to each other and to ceiling/floor slabs in three directions (degree of freedom). Transoms are fastened between the set-up mullions. If the weight of the transom loading element does not exceed 60 [kg], transoms are screwed directly to mullions. Otherwise they are slid over additional connecting members, which are then screwed to mullions. The whole forms a load bearing, truss-type structure. The spaces formed between mullions and transoms are filled with glass panes or other types of infills.

Gaps formed between the wall of the building and mullion/transom wall are covered with zinc-coated steel sheets or with anodised or powder-coated aluminium sheets, or are filled with mineral wool of different hardness.

Proper tightness of sealing between the curtain wall structure and the building is achieved by application of silicone along with polyurethane cords or by application of sealing systems based on vapour-permeable EPDM belts and vapour proof butyl belts. Detailed information regarding this issue may be obtained from manufacturers of particular sealing systems.

Lime, cement, alkaline substances and cleaning agents (e.g. bleaches, abrasive pastes) have particularly harmful effect on aluminium profiles, especially on decorative protective surfaces. Thus any “wet” works must be reduced to the minimum.

Should mortar be brought into contact with the surface of aluminium, it must be immediately washed off (its hardening must not be allowed). Failure to wash off mortar will result in permanent discolouring and will damage the surface.

#### **WARNING:**

**Lime, cement, alkaline and cleaning substances (e.g. bleaches, abrasive pastes) have particularly harmful effect on aluminium profiles, especially on decorative protective surfaces. Thus any “wet” works must be limited to the minimum.**

**Should mortar be brought into contact with the surface of aluminium, it must be immediately washed (its hardening must not be allowed). Failure to wash mortar will result in permanent discolouring and will damage the surface.**

#### 3.3 Weather sealing technology

In order to prevent water and air penetration into the inside of the facade, the MB-SR50N EFEKT system has incorporated “wet” sealing technology by the application of sealants resistant to weather conditions. The advantage of this method is full tightness of the façade and better protection of the inside of the building against noise and cold. Silicone features low thermal conductivity and resistance to high temperatures (silicone disintegrates in the temperature above 400°C).

Since finishing works are very important in the “wet” sealing method as they have a direct influence on the usable life of the façade, the recommendations presented below must be followed strictly. The order of sealing works may be broken into the following stages:

#### **Cleaning**

Depending on the structure of the surface, the following methods are employed:

- For smooth surfaces, such as glass or metal, cleaning agent recommended by the sealant manufacturer should be applied, using the technology of “two cloths”. First, the surface is wiped with a cloth moistened with the cleaning agent (pour the liquid over the cloth, never soak it in a container with cleaning agent) and then it is dried with a clean cloth. The surface is clean when the cloth remains clean and dry after wiping the surface. Do not touch the surface with hands!

- Porous surfaces, such as stone or concrete are cleaned mechanically and any loose material is removed by application of compressed air. No solvents are allowable!

**Priming**

- Application of primers should be carried out as recommended by the sealant manufacturer!
- The layer of the applied primer should be, as a rule, as thin as possible. Wipe smooth surfaces with the primer on cloth. There should be used a separate container, from which a small amount of primer is poured onto the cloth. The original container should be closed, as primers react with moisture present in the air. For this reason never pour the unused primer back into the original container for fear that the primer may lose its properties.
- In the case of porous surfaces the primer is applied with a brush, however all the remaining principles to be followed remain the same. Make sure that the material from which the brush is made does not dissolve in the primer.  
Allow the primer to dry for 15 to 60 minutes, depending on the surrounding conditions. During that time primer reacts with the substrate and the products of such a reaction and the solvent evaporate. Hence, the silicone sealant must not be applied too promptly.

**Protecting the joints**

- Areas adjacent to the joints should be protected with tapes of suitable width to prevent soiling.
- The time necessary for the tape application is sufficient for the cleaner to evaporate.
- Protecting tape should be removed immediately after tooling the sealant to ensure a neat line on the edge of sealant/glass.

**Application and shaping of silicone sealant**

- Before sealant application, insert proper insulating cord into the gap between the panes.

Such insulation cord or tape should be made of such material to which silicones do not adhere, e.g. PE (polyethylene) or PP (polypropylene) with closed pores.

- Apply silicone manually, using a proper gun to dispense the sealant from the cartridge.  
Air-powered guns ensure even application of the sealant and high precision of dispensing, which reduces the silicone losses.
- Tooling the silicone to obtain the required shape must be done immediately upon application.  
Do not use any cleaning agents used in the household, as most of them contain small amounts of silicone polymers whose function is to protect the skin.  
They form a thin layer resistant to moisture and thus the time needed for the silicone to cure is longer.  
However, you may use water and soft soap.
- With regard to the temperature of sealant application, follow recommendations of the manufacturer. In the temperatures below +5°C, there is a risk that a thin, invisible layer of ice will form. The solvent contained in the silicone, while evaporating, locally cools the surface even to the temperatures below freezing. Under such circumstances, the silicone adheres to the layer of ice and consequently it may lose its adhesive properties or there occurs a risk of leakage if the sealant does not adhere over the whole area. Too high temperature causes that the products, which should be released during the process of curing, do not evaporate from the sealant and cavities are formed, informally called "air bubbles".  
In extreme cases, such "bubbles" crack even before the process of curing has finished with the consequence that there is a leak in the façade.
- Minimum depth of the sealant joint should be at least 6 mm and maximum recommended depth is 15 mm.
- Minimum recommended width of the joint is 6-20 mm.

**3.4 Storage and transportation**

- Aluminium profiles

Aluminium profiles, details, infills, glass panels, windows and doors should be stored in dry rooms to protect elements against mechanical damage and against damage of anodised or painted coatings.

Aluminium profiles, details, infills, glass panels, windows and doors may be transported by any means of transport provided they are protected against soiling, dust and exposure to any damage during transportation.

- Fireproof materials, board

They should be stored in original packaging in horizontal position. If re-packing of inserts is required the following rules should be observed:

- inserts should be placed in a horizontal position on a flat surface (e.g. on a chipboard),
- subsequent layers should be interleaved with PE foil (e.g. thin painter's foil),
- maximum number of layers in one packaging: 25, but the stack must not be higher than 600 mm.

They should be stored in storerooms in normal weather conditions, i.e. in the temperature from 5°C to 25 °C and humidity between 50% and 80%.

After opening the packaging and taking the required number of inserts, the packaging must be covered with protective foil. The content should be protected against getting wet or drying up. The inserts should be carried carefully to avoid any damage – cracks.

### 3.5 Catalogue updates

The catalogue should be updated by downloading PDF files at (<http://www.aluprof.eu>) in the authorized section "Catalogues".

### 3.6 Availability of catalogue products

Rules and availability dates of the elements presented in the catalogue have been specified in Aluprof S.A. Price List, included in the authorised section of the website <http://www.aluprof.eu> in the section "Price Lists".

#### **WARNING:**

**Any rights to the present publication and rights to utility models included herein are vested in ALUPROF S.A. and are subject to protection pursuant to regulations on utility model rights and copyrights protection.**

**ALUPROF S.A. reserves the right to make alterations and add supplements in view of further development of the system and continuous technical enhancement.**

**The presented publication shall not be reproduced or copied in any way whatsoever without a prior written consent of ALUPROF S.A.**

**4. GRAPHIC SYMBOLS USED IN THE CATALOGUE**



Number



Notes



Total area [dm<sup>2</sup>/m]



Decorative area [dm<sup>2</sup>/m]



Angle of cut [°]



Dimensions [mm]



Number of items



Material



Standard



Working



Compatible elements

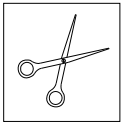

- Cut

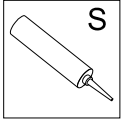

- Seal with silicone

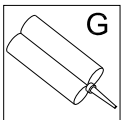

- Glue with two-component glue

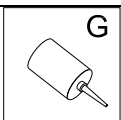

- Glue

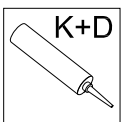

- Glue and seal

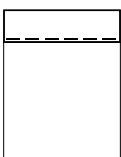

- Perform using: \_ \_ \_ \_ \_



**STATYKA  
STRUCTURAL ANALYSIS  
СТАТИКА  
STATIK**



## STRUCTURAL ANALYSIS

### 1. INTRODUCTION

Constructions made of aluminium profiles applied in the MB-SR50N EI EFEKT system require structural analysis and selection of the required cross-sections of profiles on the basis of its results. Knowledge of principles and methods of calculation for such types of structures is necessary in order to properly account for static requirements.

Diagrams and data presented in this section will help select proper aluminium profiles.

Computations included in the catalogue are simplified, i.e. they do not take into account such phenomena as:

- vibrations of a structure caused by the dynamic force of the wind,
- existence of internal pressure in buildings exposed to an open area,
- wind loads.

There is a risk of making a mistake at the stage of:

- collecting information about the structure (its location, dimensions, surrounding),
- assessment of probability of occurrence of the phenomena described above.

**ALUPROF S.A. shall bear no responsibility for faulty selection of aluminium profiles for mullions and transoms applied while assembling a curtain wall.**

### 2. DIMENSIONING METHODS

The standard EN 1990 "Basis of Structural Design" recommends dimensioning by means of limit state design method.

There are two basic limit states:

- ultimate limit state (ULS)
- serviceability limit state (SLS)

In the process of designing it should be demonstrated that neither of the limit states have been exceeded. All relevant calculation situations and load exposure types should be checked. Checking one of the limit states may be omitted providing that there is sufficient amount of information confirming that if one of the limit states is met, the criteria for the other limit state are also fulfilled.

In the case of aluminium structures of curtain walls, while dimensioning, it is recommended that serviceability limit state (SLS) be used. Relatively low rigidity of aluminium cross-section in relation to its strength causes that in most cases the value of SLS, retaining at the same time loading capacity of the cross section (SGN conditions are met). It is always the designer of the facade who makes the decision which of the two limit states is more reliable.

### 3. MATERIAL PROPERTIES OF ALLOY EN AW-6060 T66

Tensile modulus	$E = 70\,000$ [N/mm <sup>2</sup> ]
Shear modulus	$G = 27\,000$ [N/mm <sup>2</sup> ]
Poisson's ratio	$\nu = 0.3$
Coefficient of thermal expansion	$\alpha = 23 \times 10^{-6}$ [1/K]
Density	$\rho = 2700$ [kg/m <sup>3</sup> ]

**4. STRENGTH PROPERTIES OF ALLOY AW-6060 T66**

Wall thickness $t$ [mm]	Elasticity limit $f_o$ [N/mm <sup>2</sup> ]	Tensile strength $f_u$ [N/mm <sup>2</sup> ]
$t \leq 3$	160	215
$3 < t \leq 25$	150	195

**5. ALLOWABLE VALUES OF DEFLECTIONS**

With regard to maintaining rigidity of aluminium profiles (standard: EN 13830)

In respect of wind load, the maximum front deflection of framework elements of a curtain wall should not exceed:

- $L/200$  or 15 mm, depending on which value is smaller.

Maximum deflection of each horizontal framework element caused by vertical loads should not exceed:

- $L/500$  or 3 mm depending on which value is smaller.

Due to limitations of deflection of glazing edge caused by wind load or snow load, deflection of elements of the structure of a curtain wall at the height  $H$  and glazing width  $B$  should not exceed (according to standard EN 1279-5)

- $B/200$  or  $H/200$  or 12 mm, depending on which value is smaller.

**6. LOADS EXERTED ON STRUCTURES**

Curtain walls transmit external loads onto the load bearing structure of the building in points of its support. The structure may be exposed to the following loads:

- wind load (pressure or suction)
- load caused by the weight of infills (glazing, windows, panels)
- dead load
- horizontal load caused by the crowd pressure (from the inside of the building)
- snow load (for roofs, skylights and other spatial structures)

In the case of profile dimensioning by SLS method, while determining values of loads, characteristic values of loads should be applied.

Tabulating of loads exerted on structures of the facade and arranging combinations of loads is the task of the facade design engineer, who should take into account building functions and the regulations applicable in the country in which a particular structure will be used.

**7. DIMENSIONING OF CURTAIN WALL MULLION**

7.1 Determination of the moment of inertia  $I_x$  of a mullion in respect of the wind load – uniform load

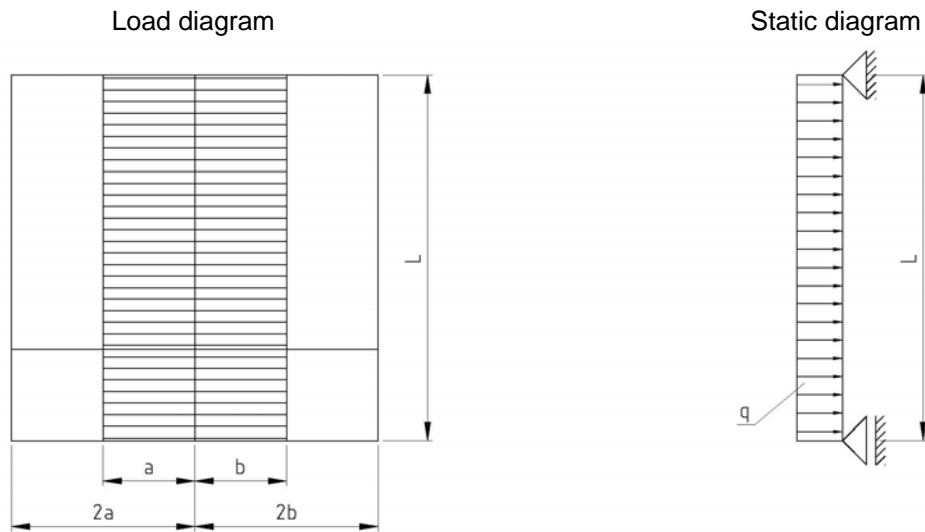

$$I_x = \frac{5 \cdot q \cdot L^4}{384 \cdot E \cdot f_{\max}} \cdot 10^5 = 18,601 \cdot \frac{(a+b) \cdot p_k \cdot L^4}{f_{\max}}$$

Where:

$q = p_k \times (a + b)$  – maximum load per profile unit length [kN/m]

$p_k$  – characteristic wind load [kN/m<sup>2</sup>]

$(a + b)$  – width of loaded area [m]

$L$  – distance between points of support [m]

$E$  – Young's modulus [GPa]

$f_{\max}$  – maximum allowable deflection of a profile [mm]

$I_x$  – moment of inertia of a mullion [cm<sup>4</sup>]

**8. DIMENSIONING OF CURTAIN WALL TRANSOM**

8.1 Determination of the moment of inertia  $I_{z1}$  of a transom in respect of the wind load – triangular load

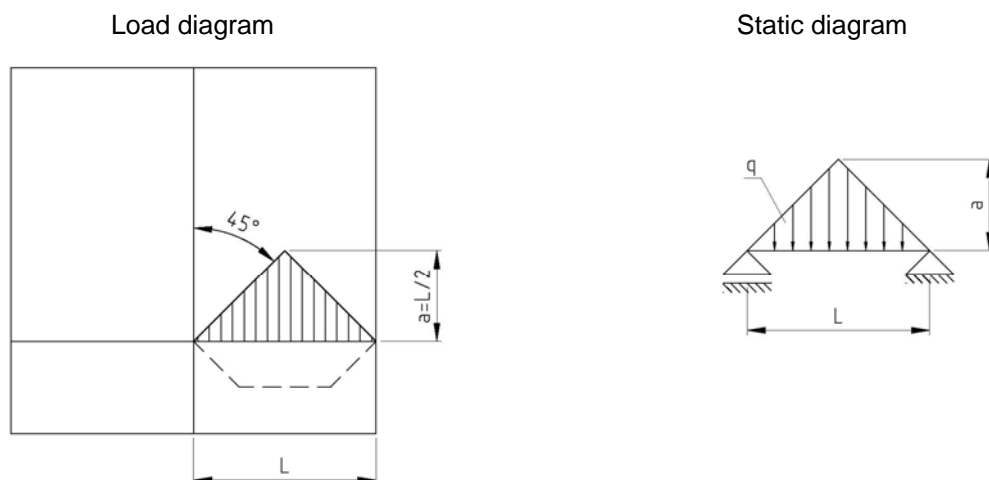

$$I_{z1} = \frac{q \cdot L^4}{120 \cdot E \cdot f_{\max}} \cdot 10^5 = 11,905 \cdot \frac{p_k \cdot a \cdot L^4}{f_{\max}}$$

Where:

$q = p_k \times a$  – maximum load per profile unit length [kN/m]

$p_k$  – characteristic wind load [kN/m<sup>2</sup>]

$a$  – height of loaded area [m]

$L$  – distance between points of support [m]

$E$  – Young's modulus [GPa]

$f_{\max}$  – maximum allowable deflection of a profile [mm]

$I_{z1}$  – moment of inertia rygla [cm<sup>4</sup>]

### 8.2 Determination of the moment of inertia $I_{z2}$ of a transom in respect of the wind load – trapezoidal load

Load diagram

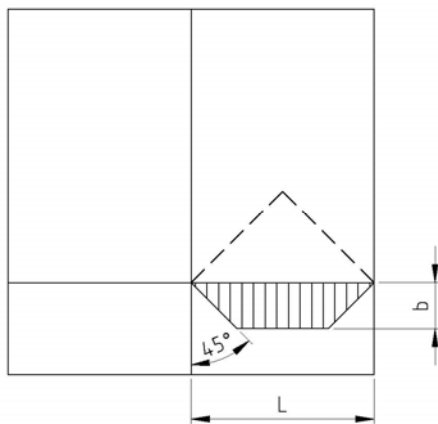

Static diagram

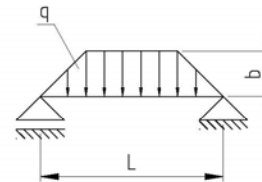

$$I_{z2} = \frac{q \cdot L^4}{1920 \cdot E \cdot f_{\max}} \cdot \left(25 - 40 \cdot \frac{b^2}{L^2} + 16 \cdot \frac{b^4}{L^4}\right) \cdot 10^5 = 0,744 \cdot \frac{p_k \cdot b}{f_{\max}} \cdot \left(5 \cdot L^2 - 4 \cdot b^2\right)^2$$

Where:

$q = p_k \times b$  – maximum load per profile unit length [kN/m],

$b$  – height of loaded area [m]

$p_k$  – characteristic wind load [kN/m<sup>2</sup>]

$L$  – distance between points of support [m]

$E$  – Young's modulus [GPa]

$f_{\max}$  – maximum allowable deflection of a profile [mm]

$I_{z2}$  – moment of inertia of a transom [cm<sup>4</sup>]

### 8.3 Determination of the moment of inertia in a transom $I_z$

In order to determine the moment of inertia in a transom  $I_z$ , exposed simultaneously to the triangular load (item 8.1) and trapezoidal load (item 8.2), the results obtained according to the formulas as above should be added.

$$I_z = I_{z1} + I_{z2}$$

8.4 Determination of the moment of inertia  $I_y$  of a transom in respect of the load cause by the weight of glazing or infills.

Load diagram

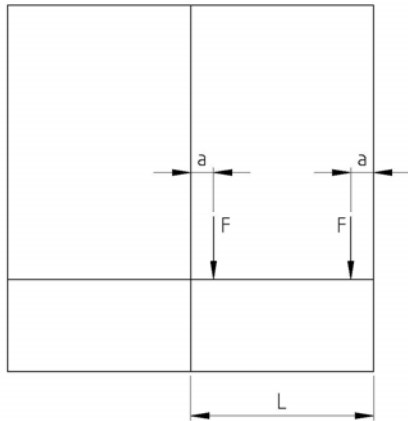

Static diagram

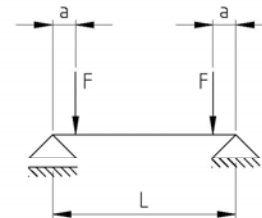

$$I_y = \frac{F \cdot a}{24 \cdot E \cdot f_{\max}} \cdot (3 \cdot L^2 - 4 \cdot a^2) \cdot 10^5 = 29,762 \cdot \frac{G \cdot a}{f_{\max}} \cdot (3 \cdot L^2 - 4 \cdot a^2)$$

Where:

$F = G/2$  – concentrated force resulting from the glazing weight [kN]

$G$  – glazing weight [kN]

$L$  – distance between points of support [m]

$a$  – distance between the point of support of glazing and the profile end [m]

$E$  – Young's modulus [GPa]

$f_{\max}$  – maximum allowable deflection of a profile [mm]

$I_y$  – moment of inertia [cm<sup>4</sup>]

## 9. ADDITIONAL LOADS

9.1 Determination of moment of inertia  $I_x$  of a mullion in respect of the load caused by crowd pressure

Load diagram

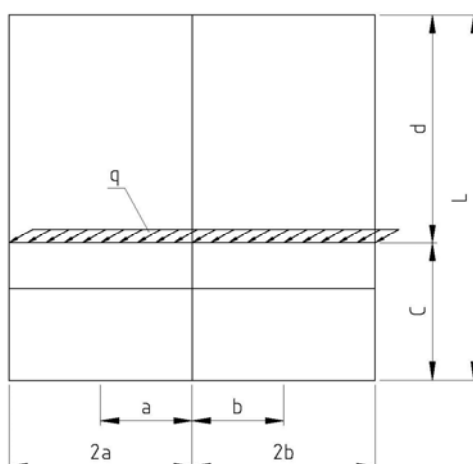

Static diagram

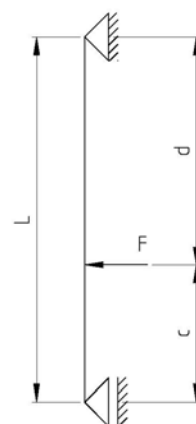

$$I_x = \frac{F \cdot d}{3 \cdot E \cdot L \cdot f_{\max}} \cdot \left[ \frac{c}{3} \cdot (L + d) \right]^{\frac{3}{2}} \cdot 10^5 = 476,19 \cdot \frac{q \cdot (a + b) \cdot d}{L \cdot f_{\max}} \cdot \left( \sqrt{\frac{c}{3} \cdot (L + d)} \right)^3$$

Where:

$F = q \times (a + b)$  – value of the concentrated load [kN]

$q$  – value of the linear load [kN/m]

$(a + b)$  – width of the loaded area [m]

$c$  – distance between the bottom fixing point and the point of force application [m]

$d$  – distance between the upper fixing point and the point of force application [m]

$L$  – distance between points of support [m]

$E$  – Young's modulus [GPa]

$f_{\max}$  – maximum allowable deflection of a profile [mm]

$I_x$  – moment of inertia [cm<sup>4</sup>]

## 10. ADDITIONAL INFORMATION

Another method of making initial selection of aluminium profiles for mullions and transoms of the curtain wall is application of the computer software MB-CAD or logiKal. Those are calculating programmes, facilitating and speeding works connected with designing, cost-estimating and preparing the production of aluminium structures.

Should there arise any doubts with regard to the appropriateness of the adopted calculation assumptions, please contact the Technical Department of ALUPROF S.A. or a specialized design office.